

INVITATION TO BID

CBD 1

BID NUMBER	RFQ: AP2551
CLOSING DATE AND TIME	MONDAY 22 APRIL 2024 STRICTLY AT 12:00PM
DESCRIPTION	MOSSELBAY: CONSTRUCTION OF A 15 X 30 SHADE NET STRUCTURE
NAME OF TENDERER/BIDDER	
CSD NUMBER	
TOTAL BID PRICE (VAT INCLUDED)	
VALIDITY PERIOD OF BID	4 CALENDAR WEEKS

SUBMISSION OF DOCUMENTS

All RFQ documents to be uploaded onto the Casidra RFQ/Tender portal. No e-mailed or hard copy documents will be accepted.

NOTE TO BIDDERS:

Bidders are required to ensure that electronic bid submissions are done at least a day before the closing date to prevent issues which they may encounter due to their internet speed, bandwidth or the size of number of uploads they are submitting. Please do not wait for the last minute to submit. A bidder can upload 30MB and up to 10 documents per upload and multiple uploads are permitted

FAILURE TO PROVIDE ANY OF THE COMPULSORY DOCUMENTATION AND PARTICULARS MAY RENDER THE BID INVALID.

THE FOLLOWING RETURNABLE DOCUMENTS (INCLUDING THE CBD FORMS AS PART OF THE BID) MUST BE VALID FOR A PERIOD OF 90 CALENDER DAYS AFTER CLOSURE OF THE BID AND SUBMITTED AS PART OF THE BID PACKET

Document	Description	Compulsory	Comment
CBD 1	Invitation to bid	✓	
CBD 2	Conditions to submit bid	✓	
CBD 3	Terms of Reference	✓	

For office use only	Version no: 1	Date: NOVEMBER 2023
To be initialled by bidder		<i>Initial here</i>

CBD 4	Pricing schedule	✓	
CBD 5	Supply Chain – Preferential Procurement Regulations 2011 and Codes of good practice	✓	

Name of bidder					
Postal address					
Street address					
Telephone number (code and number)					
Cellphone number					
Faxcimilie number (code and number)					
E-mail address					
VAT registration number					
SARS TCC attached (Foreign suppliers with no tax obligation in South Africa must complete the SBD1 form that will be submitted to SARS for verification and issuing of a Confirmation of Tax Obligation letter.)		YES	<input type="checkbox"/>	NO	<input type="checkbox"/>
Originally certified B-BBEE status level certificate/Original Sworn Affidavid <u>(A B-BBEE status level verification certificate must be delivered to Casidra SOC Ltd, 22 Louws Avenue, Paarl, in order to qualify for preference points for B-BBEE)</u>		YES	<input type="checkbox"/>	NO	<input type="checkbox"/>
CIDB Registration number	Number:	YES	<input type="checkbox"/>	NO	<input type="checkbox"/>
Registration for electrical compliance with departement of labour	Number:	YES	<input type="checkbox"/>	NO	<input type="checkbox"/>
COIDA	Number:	YES	<input type="checkbox"/>	NO	<input type="checkbox"/>

I, _____
as the authorised representative of the company / CC / business hereby declare that, to the best of my knowledge the information submitted is true and correct and that I am duly authorized as a signatory of this bid. On behalf of my business, I accept the terms and conditions as set out in this document. I will supply documentary proof of any information supplied herein on request and to the satisfaction of **Casidra**.

In terms of the POPI Act I further give consent that my contact and company details as will be captured on the **Casidra** database may be shared with the role players/funders involved in the project and be used by **Casidra** for the purpose of further procurement.

For office use only	Version no: 1	Date: NOVEMBER 2023
To be initialled by bidder		<i>Initial here</i>

Signature of bidder		Date	
Capacity under which this bid is signed			

For office use only	Version no: 1	Date: NOVEMBER 2023
To be initialled by bidder		<i>Initial here</i>

1. BID SUBMISSION:		
1.1. Bids must be delivered by the stipulated time to the correct address. Late bids will not be accepted. 1.2. All bids must be submitted on the official forms provided (not to be re-typed). 1.3. Bidders must be registered on the Central Supplier Database (CSD). 1.4. Original Sworn Affidavit and originally certified B-BBEE certificates must be submitted to bidding institution to qualify for preference points for B-BBEE. 1.5. Bids are subject to the Casidra SOC Ltd Financial Regulations, Preferential Procurement Policy Framework Act and the Preferential Procurement Regulations, 2022, the General Conditions of contract (GCC) where applicable, and if applicable other special conditions of contract.		
2. TAX COMPLIANCE REQUIREMENTS		
2.1. Bidders must ensure compliance with their tax obligations. 2.2. If a discrepancy exists between CSD and SARS, a printed version of the Tax Clearance Certificate (TCC) must be supplied by the supplier and the e-Filing PIN number for verification of authentication by Casidra SOC Ltd. 2.3. Foreign suppliers with no tax obligation in South Africa must complete SBD1 that will be submitted to SARS for verification and the issuing of a Confirmation of Tax Obligation letter. 2.4. Consortia/joint ventures/sub-contractors must each submit a separate TCC.		
3. QUESTIONNAIRE TO BIDDING FOREIGN SUPPLIERS		
3.1. Is the bidder a resident of the Republic of South Africa (RSA)	Yes <input type="checkbox"/>	No <input type="checkbox"/>
3.2. Does the bidder have a branch in RSA?	Yes <input type="checkbox"/>	No <input type="checkbox"/>
3.3. Does the bidder have a permanent establishment in the RSA?	Yes <input type="checkbox"/>	No <input type="checkbox"/>
3.4. Does the bidder have any source of income in the RSA?	Yes <input type="checkbox"/>	No <input type="checkbox"/>
IF THE ANSWER IS “NO” TO ALL OF THE ABOVE, THEN IT IS NOT A REQUIREMENT TO OBTAIN A TAX COMPLIANCE STATUS/TAX COMPLIANCE SYSTEM PIN CODE FROM THE SOUTH AFRICAN REVENUE SERVICE (SARS) AND IF NOT REGISTER AS PER 2.3 ABOVE.		
4. TENDER CONDITIONS		
CASIDRA reserves the right to: <ul style="list-style-type: none"> disregard any bids where the declaration has not been signed; accept parts of the bid items or split bids based upon item prices; disclose the results of the points awarded on request; evaluate and award points according to the documentation supplied and evaluate functionality at its own discretion; award the bid to the qualifying bidder with the highest number of points scored, unless the prices are not market related or on the basis of objective criteria stated in the tender documents, and to award the bid to a bidder which does not necessarily have the lowest price. 		
The bid may be cancelled if: <ul style="list-style-type: none"> all the bid offers received are higher than R50 million; circumstances change and there is no longer a requirement for this service; funds are no longer available or if there are insufficient funds available in the budget for the work; no acceptable bids and/or market related prices are received; there is a material irregularity in the tender process (administrative non-compliance of prescribed legislation); false information was supplied by the bidder; Cancellation of bid will be placed in the same media as initially advertised. 		
Other notes: <ul style="list-style-type: none"> Final points scored will be rounded off to the nearest 2 decimal places. In the event of equal scores, the offer with the highest B-BBEE score will be successful. If scores are still equal, and where functionality is part of the bid, the offer with the highest functionality score will be successful. If the scores are still equal, the drawing of lots will determine the outcome. Casidra SOC Ltd retains the right to amend financial/accounting calculations and to accept the amended amount as the new bid amount. 		

For office use only	Version no: 1	Date: NOVEMBER 2023
To be initialised by bidder		<i>Initial here</i>

FOR OFFICE USE ONLY

PLEASE INDICATE TYPE OF WORKS		
Infrastructure/construction (includes animal husbandry, building, greenhouses, sheds and storerooms, civil and building works including stores, engineering and electrical engineering works)	<input checked="" type="checkbox"/>	
Training	<input type="checkbox"/>	
Catering services	<input type="checkbox"/>	
Production inputs (includes feed, fertilizers, packing material, seeds and plants, transport, soil preparation)	<input type="checkbox"/>	
Professional services (Engineers, consulting engineers, Veterinarians and services, Legal Practitioners, Industrial Consultants or Recruitment Agencies, Training service providers, Subject matter specialists acting as consultants, etc.)	<input type="checkbox"/>	
Mechanisation (Vehicles, farming implements/equipment)	<input type="checkbox"/>	
Other (please specify)	<input type="checkbox"/>	
PROCUREMENT STRATEGY (Please indicate by choosing either YES or NO and click on the box.)	Yes	No
1. Advertising on e-tender	<input type="checkbox"/>	<input checked="" type="checkbox"/>
2. Advertising on CIDB	<input type="checkbox"/>	<input checked="" type="checkbox"/>
3. Advertising on Casidra portal	<input checked="" type="checkbox"/>	<input type="checkbox"/>
4. RFQ	<input checked="" type="checkbox"/>	<input type="checkbox"/>
5. Open tender process	<input type="checkbox"/>	<input checked="" type="checkbox"/>
6. Contract administration sheet completed	<input checked="" type="checkbox"/>	<input type="checkbox"/>

For office use only	Version no: 1	Date: NOVEMBER 2023
To be initialised by bidder		<i>Initial here</i>

7. Procure plan sheet completed	<input checked="" type="checkbox"/>	<input type="checkbox"/>
8. Advertise period 7 days	<input checked="" type="checkbox"/>	<input type="checkbox"/>
9. <u>*Note if bid document and advertisement period is less than 14 days, attach CEO approval.</u>	<input checked="" type="checkbox"/>	<input type="checkbox"/>
SUPPORTING DOCUMENTATION		
Project managers to indicate what supporting documentation MUST form part of the tender. If marked YES, then it must be provided to SCM:	Yes	No
Baseline Risk Assessment	<input checked="" type="checkbox"/>	<input type="checkbox"/>
Health & Safety plan	<input checked="" type="checkbox"/>	<input type="checkbox"/>
Drawings / sketches	<input checked="" type="checkbox"/>	<input type="checkbox"/>
COMPULSORY DOCUMENTATION NEEDED TO BE SUBMITTED AS PART OF THIS BID:		
COIDA – Letter of good standing	<input checked="" type="checkbox"/>	<input type="checkbox"/>
COMPANY PROFILE – Detailed company profile including but not withstanding core business activities, background, resources, etc.	<input checked="" type="checkbox"/>	<input type="checkbox"/>
CONSTRUCTION MANAGER COMPETENCY - Provide proof of competency of a construction manager in terms of Construction Regulations 2014 Clause 8 in format of CV showing competency in field of construction as well as health & safety	<input checked="" type="checkbox"/>	<input type="checkbox"/>
ELECTRICAL – Letter from department of labour for Electrical registration of sub-contractor with expiry date.	<input type="checkbox"/>	<input checked="" type="checkbox"/>
WARRANTY – Provide written proof for a 12-month warranty for product / goods offered	<input checked="" type="checkbox"/>	<input type="checkbox"/>
SERVICE AGREEMENT – Provide written proof of 3 months after sales agreement	<input type="checkbox"/>	<input checked="" type="checkbox"/>
PRODUCT BROCHURE – Provide brochure and technical specifications of product offered.	<input type="checkbox"/>	<input checked="" type="checkbox"/>

For office use only	Version no: 1	Date: NOVEMBER 2023
To be initialled by bidder		<i>Initial here</i>

MOSSSELBAY: CONSTRUCTION OF A 15 X 30M SHADE NET STRUCTURE

GENERAL REQUIREMENTS

The works, as described, are part of the Mosselbay Urban Agricultural Development Programme of the Mosselbay local Municipality for the Mosselbay area. The project is situated, in Mosselbay at the Mountain view housing development, C/O Gunter Street and Bill Geffery Avenue. The quoted amount will be a lump sum bid and must include supply, delivered and installation. The successful bidder must have the capacity to start work within Seven (7) days after appointment and complete works within 30 (thirty) calendar days.

Conditions that may pose a risk: (Summary of Risk analysis)

Staff can slip over loose items;

- Exposure to elements (sun, cold and dusty conditions);
- Injuries due to the wrong usage of tools;
- Back injuries due to lifting heavy objects and digging trenches.
- Contractor must be experienced and knowledgeable for the task and must put all necessary precautions in place to work safely under the above conditions. The Contractor must be aware of and have precautions in terms of the Occupational Health and Safety Act.

CONTRACT PERIOD

The completion period of this service is 4 calendar weeks starting from the day of appointment.

FUNCTIONAL REQUIREMENTS

Functional refers to: A service or product that is designed to be practical, useful, working or operating, taking into account factors like quality, reliability, viability, and durability and the technical capacity (time and resources) and ability (knowledge and skills) of the bidder to execute the works.

An offer that does not obtain the minimum score for each functionality criterion or the minimum weighted average for functionality as indicated, is not an acceptable tender. Is this bid subject to the evaluation of functional requirements? **YES (Casidra to indicate)**

If "YES", the following criteria will be used for evaluation:

No	Evaluation criteria	Weight (A)	Score (B)	Minimum score required	Total (A x B)
----	---------------------	------------	-----------	------------------------	---------------

For office use only	Version no: 1	Date: NOVEMBER 2023
To be initialled by bidder		<i>Initial here</i>

1	Experience of similar work	50%	For office use	4	For office use
2	Three references of similar previous work	50%	For office use	4	For office use

Functional Item	1 Poor: Non-compliant	2	3	4	5 Excellent: Fully compliant
Experience of similar work – (refer to company CV)	No experience indicated on CV	Less than 2 jobs with similar experience - Limited exposure to work at hand	Work is similar, but related.	Similar work	High level similar work
References from clients on similar nature related previous work	No references or very poor rapport by all three references	Some minor problems experienced by all three references	Moderately good by all three references	Recommended by all three references	Highly recommended by all three references

LABOUR LOG SHEETS

One of Casidra's agreed mandate with the Western Cape Department of Agriculture is to report on jobs created for the individual projects. To assist Casidra with accurate reporting it is a condition of this bid document that the successful bidder will have to submit labour log sheets with all required information properly completed.

Documentation **MUST be submitted with every payment claim** from the Contractor on a monthly basis. Failure to submit this information will result in default by the contractor and may affect payment certificates being issued.

The Protection of Personal Information Act 4 of 2013 (also known as POPIA), regulates and controls the processing, usage and storage of personal information. In order to be compliant with POPIA, Casidra commits not to share your information with any third party outside Provincial & National Departments of Agriculture, project management agencies, co-workers and associates / partners as per our business approval and evaluation, and reporting processes.

SCOPE OF WORKS

GENERAL

SITE ACCESS:

The movement of vehicles on the site should be confined to demarcated access routes and existing roads should be used where approved by the Project Manager. Any deviation should first be approved by the Project Manager in consultation with the Landowner. The Contractor should ensure that vehicles

For office use only	Version no: 1	Date: NOVEMBER 2023
To be initialled by bidder		<i>Initial here</i>

leaving the site are clean and, wherever possible do not deposit mud and any other earth material on road surfaces.

STORAGE SHEDS FOR EMPLOYEES AND MATERIALS:

The Contractor shall provide for the supply, erection and maintenance and removal on completion of the works, of ample temporary sheds for the proper storage of materials and the use of his employees.

TEMPORARY LATRINES:

The contractor shall provide for the supply and erection of proper temporary latrines for the use of his employees. Latrines are to be maintained in a thoroughly clean and orderly condition and adopt such precautions to prevent the soil from being contaminated/polluted and remove such latrines after the works.

FIRE PREVENTION MEASURES:

No unauthorized fires may be allowed inside the construction area.

(Please see the baseline risk assessment and the health and safety specification).

The Contractor shall pay damages and the costs incurred to organizations called to put out any fires started by him. The Contractor shall also pay any costs incurred to reinstate/rehabilitate burnt areas as deemed necessary by the Project Manager.

PLACING OF ORDERS:

The contractor shall place all orders for materials as early as possible, as he/she will be held responsible for any delay in the delivery thereof.

SECURITY:

The successful bidder is responsible for the security of his/her plant, facilities, resources, etc for the duration of the contract.

SITE CLEAN UP:

The Contractor shall ensure that all structures, equipment, materials, and facilities used or created on-site for or during construction activities are removed to the satisfaction of the Project Manager once the project has been completed. All roads to be repaired to at least its original condition. All damage to the site's infrastructure or land production must be repaired or rehabilitated before completion of the project

THE SCOPE OF WORKS ELEMENTS

1. Removal of vegetation
2. Concrete bases to wooden poles
3. Planting of poles
4. Installation of anchor wires
5. Installation of Wire support
6. Double gates
7. Wire tables
8. flooring

For office use only	Version no: 1	Date: NOVEMBER 2023
To be initialled by bidder		<i>Initial here</i>

REMOVAL OF VEGETATION

Clear the ground and level where the shade-net is to be constructed. This operation shall be deemed to include the digging up and removal of rubbish, debris, vegetation, hedges, shrubs, bush etc. as well as the digging up of top soil and examining for and removal of all dead roots and other vegetable matter likely to provide food for termites.

NOTE: - It must be stressed that this soil preparation must not go past the nursery platform as it will affect the stability of anchors poles

POLE SUPER STRUCTURE:

Contractor to erect structure as per the below specification and the contract drawing. Any discrepancy must be brought to the attention of the project manager during the tender process.

CONCRETE BASES TO WOODEN POLES:

Form the bases to wooden poles for the new shade-net structure with concrete (15 MPa – 1:3:6 with 19mm stone) to the forms and sizes shown on the drawings and carried up to ground level, where applicable, in properly constructed temporary formwork. The wooden poles are to be embedded in the concrete as the work proceeds and sufficient time must be allowed for the curing process to take place before anchor wires can be pulled.

POLES

All corner, intermediate and stay poles for the shade-net structure to be CCA treated hardwood round poles, to SANS 457, size for the external poles and all the internal poles to be 3600 x 100-119mm. Poles to be installed as per the layout sketch. Contractor to note the 2400mm height above ground level needed throughout the structure as required by the client.

ANCHOR WIRES & POLE

The anchor has to be fixed with fully galvanised No 8, 6mm anchor wire at a 45-degree angle. Contractor to note that the anchor wire must be wound up in its entire length. Paint the anchor wires with yellow paint high gloss to make them visible for both workers and animals. Stay cables must be attached to the perimeter poles at the same point of tension as where the horizontal cable or wire is attached.

The anchor wire must be attached to 20mm Y – Type steel bars. The bars are to be driven at a minimum depth of 900mm into the ground or deeper until solid ground is reach.

WIRE SUPPORT & INSTALLATION

Allow for both side, top and cross lines formed from high strain steel wire fully galvanised 2,24mm. Wires to be installed as per drawing. Lacing up is critical to the overall stability of the structure and to the longevity. Once cloth has been laced up and the wires tied and tensioned onto the respective poles, the cloth must be pleated like curtain material on the taut edges.

After the cross wires have been tensioned, close gap with 75mm long by 2,5mm thick cable ties at 200mm centres.

For office use only	Version no: 1	Date: NOVEMBER 2023
To be initialled by bidder		<i>Initial here</i>

SHADE CLOTH

Cover the complete structure with 40% green shade netting. Shade cloth netting to be knitted conforming to SABS standard 1703 Edition 1.02 - 2003. The shade-net to be fastened unto the steel wire running over the pole line in longitudinal direction by continuous twine in order to prevent billowing during strong winds.

DOUBLE GATES

The double gate to the openings to be of sizes to fit the opening shown and constructed out of 35mm diameter galvanised framework, mitred at angles and all welded together. Fill in the framing with 2,5mm thick, 50mm galvanised hexagon fencing material.

Each grille to hung on purpose made bullet hinges. Allow for three hinges per gate.

Provide the one gate with 1 x barrel bolts fixed to the middle of the gate and 2 x barrel bolts to the bottom of each gate as shown. Allow for concrete block as shown below the barrel bolts.

Provide the gates with a 50mm highly security locks with three (3) keys.

WIRE TABLES

A wire table of 1200mm high x 1500width X 12m long must be build. Anchors must be built with 1800 x 100-120mm poles planted 600m deep. The 80-100mm pole must be used in between, which must be fasten with bolts as per picture. 4mm anchor wire must be used to anchor. A box must be built every 4 meters along the table. The top must be covered with a netting (Jakkalproof) wire. A wire 2.2mm wire must be used, five wire lines, with 3m spacing from each other. Cable ties must be used to tighten the net wire to line wire.

FLOORING

Floor must be cleared and covered with a 250micron black plastic sheet. A 19mm PEBBLE stone will then be casted on top of the plastic to cover the floor.

CLEANING OF SITE

Contractor to allow for picking up all loose cut wire to ensure that farm animals cannot eat the waste and cause internal damage. All concrete spillage to be picked up and carted off site

TIMELINE

For office use only	Version no: 1	Date: NOVEMBER 2023
To be initialled by bidder		<i>Initial here</i>

<u>ACTION</u>	<u>START DATE</u>	<u>END DATE</u>	<u>DURATION (WEEKS)</u>
<i>Administrative and tender preparation</i>	<i>01-Apr-24</i>	<i>05-Apr-24</i>	<i>4</i>
<i>Tender runtime/sourcing of quotes</i>	<i>06-Apr-24</i>	<i>22-Apr-24</i>	<i>16</i>
<i>Adjudication and award of bid</i>	<i>22-Apr-24</i>	<i>25-Apr-24</i>	<i>3</i>
<i>Time to activate delivery</i>	<i>25-Apr-24</i>	<i>26-Apr-24</i>	<i>1</i>
<i>Construction time/delivery completed</i>	<i>26-Apr-24</i>	<i>27-May-24</i>	<i>31</i>
		<i>4</i>	<i>55</i>

BID CONDITIONS

Lump Sum Bid

No unit rate price adjustment of whatever nature, except for decreases or increases in the Value-Added Tax (VAT) and / or Variation Orders, will be applicable in this contract. The bidder shall make provision in his bid price for possible fluctuations in costs.

Premises in Occupation

The premises for the works **will** be in occupation during the contract period. Approval to access the premises must be obtained.

Fixed Price Bids

No contract price adjustment of whatever nature, except for decreases or increases in the Value-added Tax (VAT) and / or Variation Orders, shall be applicable in this contract. The Contractor will make provision in his bid for possible fluctuations in costs.

Expenses in Preparation of Bid

The Client will not be responsible for, subject to the Preferential procurement regulations, nor pay any expenses for losses which the bidder may incur in preparation of this bid.

Inspection of Site

Bidders must familiarise themselves with the local conditions, the accessibility of the site, the full extent and nature of the work to be done and the conditions affecting the execution and pricing of the bid. Claims on the grounds of lack of knowledge in such respects or otherwise will not be entertained.

Only information given in writing to the Contractor by the Engineer during the tender period will be regarded as binding on the Contract. Verbal information, given during the site inspection or at any other time prior to the award of the Contract, will not be regarded as binding on the Contract.

Site

The site to be occupied will be clearly pointed out to the Contractor at the site handover. The Contractor will not be allowed to extend his operations beyond the boundaries of the site.

Water for the Works

The Contractor may use water free of charge / pay for use at a tariff agreed with the Land Owner from the existing supply if available. He will obtain permission from the Representative / Land Owner before any connection to or

For office use only	Version no: 1	Date: NOVEMBER 2023
To be initialled by bidder	<i>Initial here</i>	

extension of the existing supply is made, which will be executed, removed and made good on completion of the works at the Contractor's own expense.

Electricity & Lighting for the Works

The Contractor may use the existing power supply if available. He will obtain permission from the Representative / Land Owner before any connection to or extension of the existing supply is made, which shall be executed, removed and made good on completion of the works at the Contractor's own expense.

The Contractor will allow for the risk of failure in the electrical supply or in case of an insufficient supply, in which case he will make his own arrangements and all costs that may arise shall be for his own account.

Scaffolding & Hoisting Equipment

The Contractor will provide for the supply, erection and removal of scaffolding and / or hoisting equipment as required.

Tools, Equipment & Machinery

The Contractor will provide all his own tools and equipment as well as facilities and transport for this project. Machinery should be sufficient to complete the works in the allocated time.

Existing Services

If the Contractor encounters any existing services such as cables, pipes or sewers during the execution of the works, he must immediately notify the Client, halting all work in the vicinity thereof, until instructions to proceed have been given by the Project Manager.

Electric wires, telephone wires, pipes, etc. will not be interfered with during the course of the contract but if it should be necessary to disconnect or cut any such wires or pipes, the Client will be advised thereof and his instruction awaited.

Accounts and Payments

Payment of accounts received by the Client in terms of the works completed, shall be affected within 30 days after receipt of a correctly completed and approved invoice for the work. The Client does not accept responsibility for delays in payment due to faulty accounts or paperwork.

Payments will be done maximum on a monthly basis and will only be made for work done/completed

Wage rates

Be responsible for all the sub-Contractors appointed by him to complete the works. A minimum of **75%** of local labour must be incorporated in the project and all workers must be SA citizens.

The following guidelines should be considered when setting rates of pay for workers:

- The rate set should take into account wages paid for comparable unskilled work in the local area per sector, if necessary.
- The rate should be an appropriate wage to offer an incentive for work, to reward effort provided and to ensure a reasonable quality of work.
- It should not be more than the average local rate to ensure people are not recruited away from other employment and jobs with longer-term prospects.
- Men, women, disabled persons and the aged must receive the same pay for work of equal value.

For office use only	Version no: 1	Date: NOVEMBER 2023
To be initialled by bidder		<i>Initial here</i>

- Provision should be made in the tender for value for payment of UIF and COIDA statutory levies.

Construction Insurance

Proof of construction insurance for planned work must be submitted by the successful contractor. If you do not have insurance, for smaller (less than R100 000) projects, Casidra can put it under its insurance portfolio for your own costs (0.5% of the contract value). We must be given enough prior notice regarding this.

Inspections, tests and analysis

All pre-bidding testing will be for the account of the contractor.

If it is a bid condition that supplies to be produced or services to be rendered should at any stage during production or execution or on completion be subject to inspection, the premises of the contractor shall be open, at all reasonable hours, for inspection by a representative of the Client or an organization acting on behalf of the Client.

If there are no inspection requirements indicated in the bidding documents and no mention is made in the contract, but during the contract period it is decided that inspections shall be carried out, the Client shall itself make the necessary arrangements, including payment arrangements with the testing authority concerned.

If the inspections, tests and analyses show the supplies to be in accordance with the contract requirements, the cost of the inspections, tests and analyses shall be defrayed by the Client.

Where the supplies or services do not comply with the contract requirements, irrespective of whether such supplies or services are accepted or not, the cost in connection with these inspections, tests or analyses shall be defrayed by the contractor.

Supplies and services which do not comply with the contract requirements may be rejected.

Any contract supplies may on or after delivery be inspected, tested or analysed and may be rejected if found not to comply with the requirements of the contract. Such rejected supplies shall be held at the cost and risk of the contractor who shall, when called upon, remove them immediately at his own cost and forthwith substitute them with supplies which do comply with the requirements of the contract. Failing such removal, the rejected supplies shall be returned at the contractor's cost and risk. Should the contractor fail to provide the substitute supplies forthwith, the Client may, without giving the supplier further opportunity to substitute the rejected supplies, purchase such supplies as may be necessary at the expense of the contractor.

The provisions of above clauses regarding inspection & testing shall not prejudice the right of the Client to cancel the contract on account of a breach of the conditions thereof, or to act in terms of the conditions of contract.

Warranty

The contractor warrants that the goods supplied under the contract are new, unused, of the most recent or current models, and that they incorporate all recent improvements in design and materials unless provided otherwise in the contract. The contractor further warrants that all goods supplied under this contract shall have no defect, arising from design, materials, or workmanship (except when the design and/or material is required by the Client's specifications) or from any act or omission of the contractor, that may develop under normal use of the supplied goods in the conditions prevailing in the country of final destination.

This warranty shall remain valid for **twelve (12) months** after the goods, or any portion thereof as the case may be, have been delivered to and accepted at the final destination indicated in the contract, or for eighteen (18) months after the date of shipment from the port or place of loading in the source country, whichever period concludes earlier, unless specified otherwise.

For office use only	Version no: 1	Date: NOVEMBER 2023
To be initialled by bidder		<i>Initial here</i>

--	--	--	--

Signature of bidder	
Date	

NOTES (applicable where indicated)
A. PRICE (where applicable)
<p>1. FIRM PRICES</p> <p>a. Only firm prices will be accepted.</p> <p>b. No non-firm prices will be considered.</p> <p>c. All delivery cost must be included in the bid price for delivery at prescribed destination.</p> <p>d. In cases where different delivery points influence the pricing, a separate pricing schedule must be submitted for each delivery point.</p> <p>2. NON-FIRM PRICES</p> <p>a. In cases of period contracts, non-firm prices will be adjusted (loaded) with the assessed contract price adjustments implicit in non-firm prices when calculated the comparative prices.</p> <p>b. Price adjustments will be allowed at periods and times specified in the bidding documents.</p> <p>c. In cases where different delivery points influence the pricing, a separate pricing schedule must be submitted for each delivery point.</p> <p>d. The quantities are given as a guideline for a bid and for the purposes of unit rates and in no way be used as a measured bid.</p> <p>3. PROFESIONAL SERVICES</p> <p>a. All applicable taxes include value-added tax, pay as you earn, income tax, unemployment insurance contributions and skills development levies.</p>
B. CONSTRUCTION (applicable to construction only)
<p>1. The total price for the service must include all labour and material required for the proper execution of the work as described in the Scope of Works and as per Engineers drawings (where applicable).</p> <p>2. The tender will be evaluated on the criteria for a market related price.</p> <p>3. The contractor must attach a detailed and comprehensive proof of competency of a construction manager in terms of Construction Regulations 2014, Clause 8 including experience regarding construction health & safety regulations.</p> <p>4. The contractor must attach the proof of CIBD grading as specified in the scope of works.</p> <p>5. The contractor must be in possession of a valid COIDA letter of good standing and it must be attached.</p> <p>6. Where applicable, the contractor must attach valid proof or registration with the Department of Labour for the installation of the main electrical supply.</p>
C. OTHER NOTES (applicable to all bids)
<p>1. The tender will be evaluated on the criteria for a market related price.</p> <p>2. The full cost of the service and/or works must be indicated and may not be discounted or cross subsidised against another service, project, transaction or sale of goods. Such contributions against the total project cost must be specified, itemised, costed and clearly indicated in the bid.</p> <p>3. The prices must be valid for a period of 90 days from date of closure of the bid to allow for evaluation and appointment.</p> <p>4. Casidra SOC Ltd retains the right to amend financial/accounting calculations and to accept the amended amount as the new bid amount.</p>
D. COMPANY PROFILE (applicable when requested)
<p>1. The contractor must attach a detailed and comprehensive company profile including core competencies of personnel. The company profile must summarize information about the organisation.</p> <p>2. The company profile must include the following:</p> <p>a. Company core business activities (describe products and services and markets in which it operates).</p> <p>b. Company background (state number of years in business, location, history of company etc.)</p> <p>c. Company resources (number of employees, core competencies of personnel, structure of company)</p>
E. WARRANTY (applicable when requested)
<p>1. Where requested, the bidder must attach proof of warranty offered on the letterhead of the bidder.</p>
F. BROCHURE (applicable when requested)

For office use only	Version no: 1	Date: NOVEMBER 2023
To be initialled by bidder		<i>Initial here</i>

1. Bidder must provide detailed brochure and technical specifications of products where requested.
2. Bidder must be able to provide proof of service location within applicable radius as specified in CBD 3 (Scope of works).
G. AFTER SALES SERVICES AGREEMENT (applicable when requested)
1. Where applicable, the bidder must sign and submit the after sales agreement.
H. APPOINTMENT (applicable to construction and professional services)
1. The successful contractor will be given notification in writing by means of an appointment letter
2. The successful contract must sign the CBD 8 , together with this document, which will form the contract.

For office use only	Version no: 1	Date: NOVEMBER 2023
To be initialled by bidder		<i>Initial here</i>

PROOF OF RELEVANT EXPERIENCE AND REFERENCES

The following must be completed in detail by bidder.

1. Supply at least **three (3)** different references from **three (3)** different companies with contact numbers.
2. **References to either complete the scoresheet which must be submitted with the bid document or provide the bidder with a reference of which a copy must be attached to the bid document.**
3. Description of work must be relevant to nature of this contract. **Do not list work if it does not fall within the scope of works.**
4. Elaborate on project under Description by being specific at to the works executed in the contract to support relevant experience.

For office use only	Version no: 1	Date: NOVEMBER 2023
To be initialled by bidder		<i>Initial here</i>

REFERENCES PROVIDED BY TENDERER

Reference company name					
Contact information					
Description of work					
Value of work					
Completed					
Performance of the contractor according below criteria:					
	Poor/bad	Done	Average	Good quality	Excellent
Quality of work					
Project time frame					
Completed within budget					
Overall management of works					
Signed by (Name)					
Signature					
Date					

For office use only	Version no: 1	Date: NOVEMBER 2023
To be initialised by bidder		<i>Initial here</i>

SUPPLY CHAIN MANAGEMENT	
PREFERENCE POINTS CLAIM FORM IN TERMS OF THE PREFERENTIAL PROCUREMENT REGULATIONS 2022 AND CODES OF GOOD PRACTICE	
Only for use of bids from R2 000 to maximum of R50 million	
<p>Casidra, as a Schedule 3D development and implementation agent for the Western Cape Provincial Government underwrites, and complies with the Provincial and National developmental initiatives and administers funds on behalf of donors. Within this context, and because of the specific requirements of the donors for the application of the funds, the awarding of bids is dependent on the special evaluation criteria as set out in the policies of Casidra. The evaluation criteria of this Preferential Procurement Policy are based on the “Preferential Procurement Policy Framework (Act 5 of 2000)” and related Regulations.</p> <p>Awarding of the bid is dependent on preferential points system, and every presentation is measured against the specific evaluation criteria as shown. The completion and signature of the document is thus a pre-requisite to qualify as a service provider.</p>	
<p>This preference form must form part of all bids invited. It contains general information and serves as a claim form for preference points for Broad-Based Black Economic Empowerment (B-BBEE) Status Level of Contribution.</p> <p>NB: BEFORE COMPLETING THIS FORM, BIDDERS MUST MAKE SURE OF THE CONTENTS OF THE BROAD BASED BLACK ECONOMIC EMPOWERMENT ACT AND THE CODES OF GOOD PRACTICE WHICH CAN BE FOUND ON:</p> <p>http://www.thedtic.gov.za/financial-and-non-financial-support/b-bbee/broad-based-black-economic-empowerment/ https://www.gov.za/documents/broad-based-black-economic-empowerment-act https://www.bbbee.commission.co.za/</p>	
DEFINITIONS	
<ul style="list-style-type: none"> 1.1 1.2 1.3 1.4 1.5 1.6 1.7 1.8 1.9 1.10 1.11 1.12 1.13 1.14 1.15 	<p>“affidavit” is a type of verified statement or showing, or in other words, it contains a verification, meaning it is under oath or penalty of perjury, and this serves as evidence to its veracity and is required for court proceedings;</p> <p>“B-BBEE” means broad-based black economic empowerment as defined in section 1 of the Broad-Based Black Economic Empowerment Act;</p> <p>“B-BBEE status level of contributor” means the B-BBEE status received by a measured entity based on its overall performance using the relevant scorecard contained in the Codes of Good Practice of Black Economic Empowerment, issued in terms of section 9(1) of the Broad-Based Black Economic Empowerment Act;</p> <p>“EME” is an Exempted Micro Enterprise with an annual total revenue of R10 million or less;</p> <p>“Large Enterprise” is any enterprise with an annual total revenue above R50 million;</p> <p>QSE is a Qualifying Small Enterprise with an annual total revenue between R10 million and R50 million;</p> <p>“the Act” means the Preferential Procurement Policy Framework Act, 2000 (Act No. 5 of 2000);</p> <p>“the Regulations” means the Preferential Procurement Regulations, 2011 and 2017;</p> <p>“consortium or joint venture” means an association of persons for the purpose of combining their expertise, property, capital, efforts, skill and knowledge in an activity for the execution of a contract;</p> <p>“person” includes a juristic person;</p> <p>“sub-contract” means the primary contractor’s assigning, leasing, making out work to, or employing, another person to support such primary contractor in the execution of part of a project in terms of the contract;</p> <p>“trust” means the arrangement through which the property of one person is made over or bequeathed to a trustee to administer such property for the benefit of another person; and</p> <p>“trustee” means any person, including the founder of a trust, to whom property is bequeathed in order for such property to be administered for the benefit of another person;</p> <p>“original sworn affidavit” means the initial document which was not photocopied or electronically reproduced;</p> <p>“original certified B-BBEE certificate” means the certification of a copy of the B-BBEE certificate confirming the validity of the original document. The stamp of the notary must be ORIGINAL.</p>

For office use only	Version no: 1	Date: NOVEMBER 2023
To be initialised by bidder	<i>Initial here</i>	

GENERAL CONDITIONS

- 1.1 The value of this bid is estimated to **not exceed R50 million** (all applicable taxes included) and therefore the 80/20 points system shall be applicable.
- 1.2 Preference points for this bid shall be awarded for:
 - (a) Price; and
 - (b) B-BBEE Status Level of Contribution.
- 1.3 The maximum points for this bid are allocated as follows:

	POINTS
PRICE	80
B-BBEE STATUS LEVEL OF CONTRIBUTION	20
Total points for Price and B-BBEE	100

- 1.4 Failure on the part of a bidder to fill in, sign this form and submit in the circumstances prescribed in the Codes of Good Practice either a B-BBEE Verification Certificate form issued by a Verification Agency accredited by the South African Accreditation System (SANAS) or by a Registered Auditor approved by the Independent Regulatory Board of Auditors (IRBA) or an affidavit confirming annual total revenue and level of black ownership together with the bid, will be interpreted to mean that preference points for B-BBEE status level of contribution are not claimed.
- 1.5 The purchaser reserves the right to require of a bidder, either before a bid is adjudicated or at any time subsequently, to substantiate any claim in regard to preferences, in any manner required by the purchaser.
- 1.6 The bidder is responsible to provide **Casidra SOC Ltd** with (refer to 2.2 under POINTS AWARDED FOR PRICE:
 - 1.6.1. An **original sworn affidavit**
 - 1.6.2. An **originally certified B-BBEE certificate**.

ADJUDICATION USING A POINT SYSTEM

- 1.1 Subject to Regulation 7 of the **Casidra SOC Ltd** Financial Regulations and PPR 2022, the bidder obtaining the highest number of total points will be awarded the contract.
- 1.2 Preference points shall be calculated after prices have been brought to a comparative basis taking into account all factors of non-firm prices and all unconditional discounts.
- 1.3 Points scored must be rounded off to the nearest 2 decimal places.
- 1.4 In the event that two or more bids have scored equal total points, the successful bid must be the one scoring the highest number of preference points for B-BBEE.
- 1.5 However, where functionality criterion forms part of the bid and is part of the evaluation process, and two or more bids have scored equal points including equal preference points for B-BBEE, the successful bid must be the one scoring the highest score for functionality.

POINTS AWARDED FOR PRICE

THE 80/20 PREFERENCE POINT SYSTEM

- 1. A maximum of 80 points is allocated for price on the following basis:

$$P_s = 80 \left(1 - \frac{P_t - P_{min}}{P_{min}} \right)$$

Where
 P_s = Points scored for price of tender under consideration
 P_t = Rand value of offer tender consideration
 P_{min} = Rand value of lowest acceptable tender

- 2. A maximum of 20 points will be awarded for B-BBEE status level of contribution:
 - 2.1. In terms of Regulations 5(2) of the Regulations preference points must be awarded to a bidder for attaining the B-BBEE status level of contribution in accordance with the table below:

B-BBEE Status Level on Contributor	Number of points	Points awarded (for office use only)	BEE recognition level
1	20	EME & QSE 100% Black owned	135%
2	18	EME & QSE 51% + Black	125%
3	14		110%
4	12	EME 51% < Black owned	100%
5	8		80%
6	6		60%
7	4		50%

For office use only	Version no: 1	Date: NOVEMBER 2023
To be initialled by bidder		<i>Initial here</i>

8	2		10%
Non-compliant contributor	0		0%

2.2. B-BBEE requirements:

An **EME** must submit a valid, fully completed, **original, certified, dated and signed sworn affidavit** (no photostat copies of certification allowed) confirming annual turnover and level of black ownership or an affidavit issued by Companies Intellectual Property Commission (accounting officer for a Closed Corporation).

If a **startup EME**, a **clear, originally certified copy**, of B-BBEE certificate issued by the CIPC for EME's only is accepted.

A **QSE that is less than 51% (50% or less) black owned** must be verified in terms of the QSE scorecard issued via Government Gazette and submit a **clear, valid, originally certified copy** of a B-BBEE Verification Certificate issued by SANAS.

A **QSE that is at least 51% black owned (51% or higher)** must submit an **original, certified, dated and signed sworn affidavit** confirming turnover and level of black ownership as well as declare its empowering status or an affidavit issued by Companies Intellectual Property Commission.

A **large enterprise** must submit a **clear, valid, originally certified copy** of a B-BBEE Verification Certificate issued by a verification agency accredited by SANAS.

A **trust, consortium or joint venture**, will qualify for points for their B-BBEE status level as a legal entity, provided that the entity submits their B-BBEE status level certificate.

A **trust, consortium or joint venture** (including unincorporated consortia and joint ventures) must submit a consolidated B-BBEE status level verification certificate for every separate tender.

Tertiary institutions and public entities will be required to submit their B-BBEE status level certificates in terms of the specialized scorecard contained in the B-BBEE Codes of Good Practice.

3. Bids of non-compliant contributors (where no certificate was submitted) will be considered but no points will be awarded for B-BBEE status.

DECLARATION

Bidders who claim points in respect of B-BBEE status level of contribution **MUST** complete the following:

1. B-BBEE status level of contributor claimed in terms of paragraph 1 and 2 above:

B-BBEE status level of contributor:

2. SUB-CONTRACTING

2.1. Will any portion of the contract be sub-contracted: Yes No
(Tick applicable box)

2.2. If YES, INDICATE:

a. What percentage of contract will be subcontracted?

b. The name of the subcontractor

c. B-BBEE status level of the sub-contractor

d. Is sub-contractor EME or QSE Yes No

e. Attach the **originally certified** B-BBEE certificate/**original** sworn affidavit as proof.

MARKET RELATED PRICING

If a bidder, whose tender is compliant and received the highest overall points, do not offer a market related price, the offer may be negotiated with that bidder to be market related.

Are you willing to negotiate your offer? Yes No

SUPPLY CHAIN PERFORMANCE MEASUREMENT

For office use only	Version no: 1	Date: NOVEMBER 2023
To be initialled by bidder		<i>Initial here</i>

In order for **Casidra** to measure its supply chain efficiency and effectiveness, please assist us by answering the following questions:

- **What were the source that made you became aware of this bid being available.**

Personal Email invite to bid:	<input type="checkbox"/>
Via a friend or business partner:	<input type="checkbox"/>
National Government E-Tender website:	<input type="checkbox"/>
Local Newspapers:	<input type="checkbox"/>
Casidra own website:	<input type="checkbox"/>
CIDB website	<input type="checkbox"/>
Other (specify)	<input type="checkbox"/>

- **Was the time allowed to date of closure sufficient for you to compile an offer?**

No – too short <input type="checkbox"/>	Yes – Sufficient <input type="checkbox"/>	No - Too long <input type="checkbox"/>
---	---	--

I, _____

as the authorised representative of the company / CC / business hereby declare that, to the best of my knowledge the abovementioned information is true and correct and that I am duly authorized as a signatory of this bid. On behalf of my business, I accept the terms and conditions as set out in this document. I will supply documentary proof of any information supplied herein on request and to the satisfaction of **Casidra**.

In terms of the POPI Act I further give consent that my contact and company details as will be captured on the **Casidra** database may be shared with the role players/funders involved in the project and be used by **Casidra** for the purpose of further procurement.

Signature	
Date	

For office use only	Version no: 1	Date: NOVEMBER 2023
To be initialled by bidder		<i>Initial here</i>



DECLARATION OF INTERESTS, BIDDERS' PAST SCM PRACTICES AND INDEPENDENT BID DETERMINATION

1. To give effect to the requirements of the Western Cape Provincial Treasury Instructions, 2019: Supply Chain Management (Goods and Services), Practice Note 4 of 2006 Declaration of Bidders Past SCM Practices-(SDB8), Instruction note Enhancing Compliance Monitoring and Improving Transparency and Accountability in Supply Chain Management SBD 4 Declaration of Interest, Practice Note 2010 Prohibition of Restrictive practices SBD9, Section 4 (1) (b) (iii) of the Competition Act No. 89 of 1998 as amended together with its associated regulations, the Prevention and Combating of Corrupt Activities Act No 12 of 2004 and regulations pertaining to the tender defaulters register, Paragraph 16A9 of the National Treasury Regulations and/or any other applicable legislation.
2. All prospective bidders intending to do business with this institution must be registered on the central supplier database.
3. Definitions:

“**Bid**” includes a price quotation, advertised competitive bid, limited bid or proposal

“**Bid rigging (or collusive bidding)**” occurs when businesses, that would otherwise be expected to compete, secretly conspire to raise prices or lower the quality of goods and / or services for purchasers who wish to acquire goods and / or services through a bidding process. Bid rigging is, therefore, an agreement between competitors

“**business interest**” means —

- (a) a right or entitlement to share in profits, revenue or assets of an entity;
- (b) a real or personal right in property;
- (c) a right to remuneration or any other private gain or benefit, and includes any interest contemplated in paragraphs (a), (b) or (c) acquired through an intermediary and any potential interest in terms of any of those paragraphs;

“**Consortium or Joint Venture**” means an association of persons for the purpose of combining their expertise, property, capital, efforts, skill and knowledge in an activity for the execution of a contract;

“**employee**” means a person employed by the Provincial Government, a provincial public entity or a business enterprise, whether permanently or temporarily, including –

- a) an employee as contemplated in section 8 of the Public Service Act, 1994 (Proclamation 103 of 1994);
- b) a person appointed in terms of section 12A of the Public Service Act;
- c) a person transferred or seconded to the Provincial Government or a provincial public entity in terms of section 15 of the Public Service Act; and
- d) an educator as defined in the Employment of Educators Act, 1998 (Act 76 of 1998), and includes a member of the board or other controlling body of a provincial public entity;

“**entity**” means any —

- a) association of persons, whether or not incorporated or registered in terms of any law, including a company, corporation, trust, partnership, close corporation, joint venture or consortium; or
- b) sole proprietorship;

“**entity conducting business with the Institution**” means an entity that contracts or applies or tenders for the sale, lease or supply of goods or services to the Province;

“**Family member**” means a person’s —

- a) spouse; or
- b) child, parent, brother or sister, whether such a relationship results from birth, marriage or adoption.

If you know of any corrupt, fraudulent or collusive actions in the Institution, please report it by submitting the REPORT FRAUD on the Casidra SOC Ltd website <https://casidra.co.za/report-fraud/>. This registration form must be completed annually. Should the information herein declared change in the course of the year or before the next renewal or in relation to any bid, quotation or contract, it is the entity’s responsibility to advise the Institution in writing of the change in such details.

For office use only	Version no: 1	Date: NOVEMBER 2023
To be initialed by bidder		<i>Initial here</i>

“intermediary” means a person through whom an interest is acquired, and includes—

- a) a person to whom is granted or from whom is received a general power of attorney; and
- b) a representative or agent;

“Institution” in this regard means — **Casidra SOC Ltd**

“Provincial Government Western Cape (PGWC)” means the Institution of the Western Cape, and a provincial public entity;

“spouse” means a person’s:

- a) partner in marriage;
- b) partner in a customary union according to indigenous law; or
- c) partner in a relationship in which the parties live together in a manner resembling a marital partnership or customary union;

4. Regulation 13(c) of the Public Service, 2016, effective 1 February 2017, prohibits any employee from conducting business with an organ of state, or holding a directorship in a public or private company doing business with an organ of state unless the employee is a director (in an official capacity) of a company listed in schedules 2 and 3 of the Public Finance Management Act.
5. The bid of any bidder may be disregarded if that bidder or any of its directors have abused the institution’s supply chain management system; committed fraud or any other improper conduct in relation to such system; or failed to perform on any previous contract.
6. Section 4 (1) (b) (iii) of the Competition Act No. 89 of 1998, as amended, prohibits an agreement between, or concerted practice by firms, or a decision by an association of firms, if it is between parties in a horizontal relationship and if it involves collusive bidding (or bid rigging). Collusive bidding is a per se prohibition meaning that it cannot be justified under any grounds.
7. Communication between partners in a joint venture or consortium will not be construed as collusive bidding.
8. In addition and without prejudice to any other remedy provided to combat any restrictive practices related to bids and contracts, bids that are suspicious will be reported to the Competition Commission for investigation and possible imposition of administrative penalties in terms of section 59 of the Competition Act No 89 of 1998 and or may be reported to the National Prosecuting Authority (NPA) for criminal investigation and or may be restricted from conducting business with the public sector for a period not exceeding ten (10) years in terms of the Prevention and Combating of Corrupt Activities Act No 12 of 2004 or any other applicable legislation.

SECTION A: DETAILS OF THE ENTITY	
A1.	Name of the Entity
A2.	Entity registration Number (where applicable)
A3.	Entity Type
A4.	Tax Reference Number
A5. Full details of directors, shareholder, member, partner, trustee, sole proprietor or any persons with a right or entitlement to share in profits, revenue or assets of an entity, of the entity should be disclosed in the Table A below.	

If you know of any corrupt, fraudulent or collusive actions in the Institution, please report it by submitting the REPORT FRAUD on the Casidra SOC Ltd website <https://casidra.co.za/report-fraud/>. This registration form must be completed annually. Should the information herein declared change in the course of the year or before the next renewal or in relation to any bid, quotation or contract, it is the entity’s responsibility to advise the Institution in writing of the change in such details.

For office use only	Version no: 1	Date: NOVEMBER 2023
To be initialed by bidder		<i>Initial here</i>

SECTION C: PERFORMANCE MANAGEMENT AND BIDDER'S PAST SUPPLY CHAIN MANAGEMENT PRACTICES

To enable the prospective bidder to provide evidence of past and current performance with the Institution.

C1.	Did the entity conduct business with the Institution in the last twelve months? (If yes complete Table C)	YES	NO
		<input type="checkbox"/>	<input type="checkbox"/>

C2. Table C

Complete the below table to the maximum of the last 5 contracts.

NAME OF CONTRACTOR	PROVINCIAL DEPARTMENT OR PROVINCIAL ENTITY	TYPE OF SERVICES OR COMMODITY	CONTRACT / ORDER NUMBER	PERIOD OF CONTRACT	VALUE OF CONTRACT

C3.	Is the entity or its principals listed on the National Database as companies or persons prohibited from doing business with the public sector?	NO	YES
C4.	Is the entity or its principals listed on the National Treasury Register for Tender Defaulters in terms of section 29 of the Prevention and Combating of Corrupt Activities Act (No. 12 of 2004)? (To access this Register, enter the National Treasury's website, www.treasury.gov.za , click on the icon "Register for Tender Defaulters" or submit your written request for a hard copy of the Register to facsimile number (012) 3265445.)	NO	YES
C5.	If yes to C3 or C4, were you informed in writing about the listing on the database of restricted suppliers or Register for Tender Defaulters by National Treasury?	NO	YES
C6.	Was the entity or persons listed in Table A convicted for fraud or corruption during the past five years in a court of law (including a court outside the Republic of South Africa)?	NO	YES

If you know of any corrupt, fraudulent or collusive actions in the Institution, please report it by submitting the REPORT FRAUD on the Casidra SOC Ltd website <https://casidra.co.za/report-fraud/>. This registration form must be completed annually. Should the information herein declared change in the course of the year or before the next renewal or in relation to any bid, quotation or contract, it is the entity's responsibility to advise the Institution in writing of the change in such details.

For office use only	Version no: 1	Date: NOVEMBER 2023
To be initialed by bidder	<i>Initial here</i>	

SECTION D: DULY AUTHORISED REPRESENTATIVE TO DEPOSE TO AFFIDAVIT

The form should be signed by a duly authorized representative of the entity before a commissioner of oaths.

I, hereby swear/affirm;

- i. that the information disclosed above is true and accurate;
- ii. that I understand the content of the document;
- iii. that I have arrived at the accompanying bid independently from, and without consultation, communication, agreement or arrangement with any competitor In addition, that there will be no consultations, communications, agreements or arrangements with any competitor regarding the quality, quantity, specifications and conditions or delivery particulars of the products or services to the Institution.;
- iv. that there have been no consultations, communications, agreements or arrangements made with any official of the procuring institution in relation to this procurement process prior to and during the bidding process except to provide clarification o the bid submitted where so required by the institution; and that my entity was not involved in the drafting of the specifications or terms of reference for this bid;
- v. that I or the representative of the company are aware of and undertakes not to disclose the terms of any bid, formal or informal, directly or indirectly, to any competitor, prior to the awarding of the contract.

DULY AUTHORISED REPRESENTATIVE'S SIGNATURE

I certify that before administering the oath/affirmation I asked the deponent the following questions and wrote down his/her answers in his/her presence:

- 1.1. Do you know and understand the contents of the declaration?
ANSWER:
- 1.2. Do you have any objection to taking the prescribed oath?
ANSWER:
- 1.3. Do you consider the prescribed oath to be binding on your conscience?
ANSWER:
- 1.4. Do you want to make an affirmation?
ANSWER:

I certify that the deponent has acknowledged that he/she knows and understands the contents of this declaration, which was sworn to/affirmed before me and the deponent's signature/thumbprint/mark was place thereon in my presence.

.....
SIGNATURE and FULL NAMES

Commissioner of Oaths

Designation (rank) ex officio: Republic of South Africa

Date:Place

Business Address:

If you know of any corrupt, fraudulent or collusive actions in the Institution, please report it by submitting the REPORT FRAUD on the Casidra SOC Ltd website <https://casidra.co.za/report-fraud/>. This registration form must be completed annually. Should the information herein declared change in the course of the year or before the next renewal or in relation to any bid, quotation or contract, it is the entity's responsibility to advise the Institution in writing of the change in such details.

For office use only	Version no: 1	Date: NOVEMBER 2023
To be initialed by bidder		<i>Initial here</i>



RFQ AP2551

MOSSELBAY: CONSTRUCTION OF 30 X 15 SHADE NET STRUCTURE

APRIL 2024

BASELINE RISK ASSESMENT REPORT

A baseline risk assessment focuses on the identification of risk that applies to the whole project. The purpose of conducting a baseline risk assessment is to establish a risk profile.

This is an initial risk assessment that focuses on a broad overview in order to determine the risk profile to be used in subsequent risk assessments. It is performed to obtain a benchmark of the types and size of potential hazards, which could have a significant impact on the whole project and all stakeholders.

The stakeholders need to identify the major and significant risks, then prioritise these risks and evaluate the effectiveness of current systems for risk control.

The risks for the above project which have been identified have been highlighted under the following categories:-

1. Scope of work (what is being built?)

This project consists of the following elements:

1. **CONSTRUCTION OF 30 X 15 SHADE NET STRUCTURE CBD3 and drawings (Scope of works)**
2. **Location of site and elements specific to the location (municipal by-laws, weather factors, geographical factors)**

The project is situated, in Mosselbay urban area. On the gravel road on your way to De Rust. The climate here is considered to be a local steppe climate. The climate is warm and temperate in Mossel Bay. The precipitation levels in Mossel Bay are noteworthy, as there is rainfall even during the most arid month. The Köppen-Geiger climate classification is Cfb. The mean yearly temperature recorded in Mossel Bay is 17.0 °C,

For office use only	Version no: 2	Date: 20 October 2014	
To be signed upon appointment of winning bidder to form the agreement between the parties			
Signature for Casidra		Signature for Contractor	

as per the available data. The annual precipitation in this location is approximately 534 mm.

The onset of summer commences towards the conclusion of June and culminates by September. The season is characterized by a sequence of months, namely: June, July, August, September.

3. Geo- technical risks (conditions of the soil, raise any concerns that may hinder the project progress)

The site consists of sandy soil conditions, during high rainfalls, the soil can be waterlogged.

4. Environmental risks (This is the actual or potential threat of adverse effects on living organisms and environment by effluents, emissions, wastes, resource depletion, etc involved in the construction phase)

Due to the site being in an environmental area there is always the risk for soil, groundwater and surface water pollution and contamination when using mechanical plant, fuel and pesticides. It will also not be allowed to dispose of any kind of waste by burying it on site.

5. Risk assessments based on scope of work (Is this a high rise building in a built up area? Is it working in a flood plain and/or river with eroded soil conditions?)

Due to the nature of the works, there is risk of maintaining structural stability during excavations. Dangers presented are the collapse of excavations, falling or dislodging material and falling into excavations.

The erection of steel framework presents its own dangers on both the erection of heavy steel sections and installation of roof plastics, especially at height. Care must be taken during the erection process with mechanical equipment working in close proximity to site labour force.

Working at height poses risks of falling, material/tools dropping down damaging infrastructure and/or personnel. People are struck by material falling from loads being lifted and material that rolls or is kicked off work platforms; others are struck or buried by falling materials. Structures under construction may also collapse, eg steel frames that have not been adequately braced, or formwork that is prematurely loaded.

6. Equipment Risks.

The equipment risks associated with this project is as follows:-

For office use only	Version no: 2	Date: 20 October 2014	
To be signed upon appointment of winning bidder to form the agreement between the parties			
Signature for Casidra		Signature for Contractor	

It is envisaged that this will be both a mechanised and labour job. There will be mechanised earth moving equipment in close proximity to people, infrastructure, and surrounding environment.

7. Material Risks.

The following could pose risks associated with the project:-

- Flammable materials such as diesel/petrol in a highly flammable environment.
- Inhalation of poison or being in contact with skin
- Care must be taken not to dispose of any material by burning

8. Ergonomic Risks (Ergonomic hazards refer to workplace conditions that pose the risk of injury to the musculoskeletal system of the worker).

Cold conditions. Dangers associated with pneumonia. During winter season.

Manual handling

Lifting heavy and awkward loads causes back and other injuries. Some injuries can result from a single lift, but more commonly, long-term injury develops as a result of repeated minor injury due to repetitive lifting.

Noise and vibration

High levels of noise can cause hearing loss and repeated use of vibrating tools can cause hand-arm vibration syndrome (damage to nerves and blood vessels – most commonly in the hands and fingers).]

Chemicals

Exposure to materials such as cement and solvents can cause skin problems such as dermatitis.

9. Controls specific to client requirements (two day induction, pink overalls, entrance to existing premises, etc).

N/A

RISK OVERVIEW CHART FOR PROJECT:

RISK CATEGORY	RISK FACTOR	ASSOCIATED RISK	RISK PROBABILITY FACTOR (1-5) 1 being low 5 being very high
LOCATION	Cool temperatures	Pneumonia	2

For office use only	Version no: 2	Date: 20 October 2014	
To be signed upon appointment of winning bidder to form the agreement between the parties			
Signature for Casidra		Signature for Contractor	

GEOGRAPHICAL	Very loose sandy soil	Windstorms and risk of collapse of ground when excavating or open excavations	3
ENVIRONMENTAL	Dust pollution	Dust will affect both neighboring & current farmers crops	3
	Soil contamination	Risk of pollution to ground by contaminants	3
	High winds	Risk of damage to construction materials and risk of being blown off structure	4
SCOPE OF WORK	Structural stability	Risk that people be killed or seriously injured by collapses and falling materials while working in excavations	3
	Working at Heights	Risk of falling material and/or personnel	4
	Site enclosure	Risks to public if not managed and implemented	4
EQUIPMENT	Mechanised plant working with labour	Risk of injury to labour force due to close proximity	5
MATERIAL	Flammable material	Dangerous to work with and to store	3
ERGONOMIC	Manual handling	Lifting of heavy equipment High noise levels	4
	Noise/Vibration	Exposure to chemicals	4
	Chemicals	Heat exhaustion	4
	Heat		4

For office use only	Version no: 2	Date: 20 October 2014	
To be signed upon appointment of winning bidder to form the agreement between the parties			
Signature for Casidra		Signature for Contractor	

CLIENT REQUIREMENTS	Working times	No work is to be done after 17h00 at night	3
----------------------------	---------------	--	---

For office use only	Version no: 2	Date: 20 October 2014	
To be signed upon appointment of winning bidder to form the agreement between the parties			
Signature for Casidra		Signature for Contractor	

Please find below risk assessment template which can be used by the contractor to manage the above identified risks.

Risk assessment							
Title:							
Company name:			Date assessment was carried out:				
Assessment carried out by:			Date of next review:				
Risk assessment Activity or area	What are the hazards?	Who might be harmed and how?	What are you already doing?	What further action do you need to take?	Who needs to carry out the action?	When is the action needed by?	Done

For office use only	Version no: 2	Date: 20 October 2014	
To be signed upon appointment of winning bidder to form the agreement between the parties			
Signature for Casidra		Signature for Contractor	



RFQ AP02188

MOSSELBAY: CONSTRUCTION OF 30 X 15 SHADE NET STRUCTURE

March 2024

OCCUPATIONAL HEALTH & SAFETY SPECIFICATION

In terms of the Construction Regulations 2014 Regulation 5, a baseline risk assessment for the intended works is required to be done by the Client for each specific construction site.

This risk assessment will inform the site specific Occupational Health and Safety specifications that must be supplied to the designer, who will supply any design specifications to be added and then supplied to the prospective Contractor (Bidder) as part of the tender documents. This specification must be translated into actions and preventative risk management measures by the Contractor that will form part the Occupational Health and Safety Plan of the Contractor.

This specification forms an integral part of the contract, and the Contractor is required to use it at pre-tender phase to make sufficient provision for related costs for risk management and after award of tender for the purpose of drawing up its project-specific construction phase health and safety plan.

It is the responsibility of the Contractor in the bidding process to:

- ensure that he include adequate provision for the cost for health and safety measures in his bid and
- Provide proof and include in his cost the necessary competencies and resources to perform the work safely.

The risks for the above project which have been identified, evaluated and resulted in the following specifications that are highlighted under the following categories:-

This specification does not replace the requirement of the Contractor to comply to all relevant legislation and the regulations of the Occupational Health and Safety Act, but just highlight the specific identified and relevant risk factors that need special mention and attention by the Contractor in his bid.

1. General administrative requirements

DESIGNATION	NAME	CONTACT	ADDRESS	RESPONSIBLE
-------------	------	---------	---------	-------------

For office use only	Version no: 2	Date: 20 October 2014		
To be signed upon appointment of winning bidder to form the agreement between the parties				
Signature for Casidra		Signature for Contractor		

		NO's		PERSON
Project Client	Casidra SOC	044 873 4186	Bateleur Park, Cradock Street, George	Warren Marcus Project Manager
Municipality	Mosselbay local Municipality	044 606 5000	101 Marsh Street Mosselbay, 6500	N/A
Project Funder	Mosselbay local Municipality	044 606 5245	101 Marsh Street Mosselbay, 6500	Gwynnefer Harding

2. Scope of work (what is being built?)

This project consists of the following elements:

**CONSTRUCTION OF 30 X 15 SHADE NET STRUCTURE CBD3 and drawings
(Scope of works)**

3. Location of site and elements specific to the location (municipal by-laws, weather factors, geographical factors)

What is the risk?	Cold and rain
Hazard Identification?	High temperatures together with high wind factor.
Who will be injured & mechanism of injury?	All personnel working on site. Possible injury will vary from pneumonia and or broken ankles from muddy soil.
Preventative action recommended	
Description	Category: Reduction/transfe r/control/avoidan ce
<ul style="list-style-type: none"> Monitor weather for worsening soil conditions on daily basis. When conditions underfoot do not assist with mechanical and/or personnel, call site off until conditions improve Ensure for shade and sufficient water onsite for high temperatures. Ensure temperature is monitored and call site off with WGT of 40 and higher 	Risk reduction/ control

For office use only	Version no: 2	Date: 20 October 2014
To be signed upon appointment of winning bidder to form the agreement between the parties		
Signature for Casidra		Signature for Contractor

What is the risk?	Wind
Hazard Identification?	High winds are experienced in the area and danger of falling off temporary and/or permanent structures
Who will be injured & mechanism of injury?	All personnel working at height. Possible injury will vary from dislocation, broken bones to death by falling.
Preventative action recommended	
Description	Category: Reduction/transfer/control/avoidance
<ul style="list-style-type: none"> All temporary structures to be designed and erected to withstand high winds. All fall protection must be in place before workers can access platforms Subcontract temporary platform erection to a specialist and they then bear all responsibility of erected temporary platforms All people working at heights must have a harness. Install wind meter on site with siren warning for wind speeds above 40km/h. Work at heights will stop until wind subsides 	<ul style="list-style-type: none"> Risk reduction/mitigation Risk transfer Risk control Risk avoidance

4. Geo- technical risks (conditions of the soil, raise any concerns that may hinder the project progress)

What is the risk?	Soil conditions
Hazard Identification?	Sandy soil conditions and soggy when wet
Who will be injured & mechanism of injury?	Infrastructure damage, damage to earthmoving equipment and personnel injury will vary from dislocation, broken bones to death
Preventative action recommended	
Description	Category: Reduction/transfe r/control/avoidan ce
This is specialized work that requires competent human resources that are adequately skilled in working with locating unknown services and dealing with them when located. Heavy and dangerous machinery in loose sandy soil conditions when also require skill set.	Risk control

For office use only	Version no: 2	Date: 20 October 2014
To be signed upon appointment of winning bidder to form the agreement between the parties		
Signature for Casidra		Signature for Contractor

5. Environmental risks (This is the actual or potential threat of adverse effects on living organisms and environment by effluents, emissions, wastes, resource depletion, etc involved in the construction phase)

What is the risk?	Soil contamination	
Hazard Identification?	Risk of pollution to ground and river by its contaminants	
Who will be injured & mechanism of injury?	Environment and this invariably falls over to communities, which then in affect the members of the public	
Preventative action recommended		
Description	Category: Reduction/transfe r/control/avoidan ce	
<p>Maintenance and service areas should be demarcated during site establishment and all maintenance and service activities contained so as to avoid any contamination of soil and / or water. All vehicles, equipment, fuel and petroleum services and tanks should be maintained in a good condition that prevents leakage and possible contamination of soil or water supplies. Refuelling areas should be bunded and lined to prevent spilled fuels and oils from contaminating the ground or water. It is suggested that as a minimum, sandbags should be placed surrounding the bulk fuel supply tank. The floor of the area is to be lined with plastic and a layer of sand of approximately 50mm is placed on top of the plastic. Automatic shut-off nozzles are recommended on all dispensing units.</p> <p>The park and service area should be treated with a suitable hydrocarbon absorption or remediation product. Absorbent spill mop-up products should to be on hand. All servicing should be done with a drip tray present to prevent accidental spillage of oils and fuels. A suitable leak proof container for the storage of oiled equipment (filters, drip tray contents and oil changes, etc.) should be established. All spills to be immediately contained, reported to the Project Manager, and dealt with.</p>	Risk control/ reduction	

What is the risk?	Snakes	
Hazard Identification?	Being bitten by snakes	
Who will be injured & mechanism of injury?	Personnel working on site	
Preventative action recommended		
Description	Category:	

For office use only	Version no: 2	Date: 20 October 2014	
To be signed upon appointment of winning bidder to form the agreement between the parties			
Signature for Casidra		Signature for Contractor	

	Reduction/transfe r/control/avoidan ce
<p>As the work entails working in dense brush and biomass areas, the risk of disturbing a snake is very high. Make sure that all personell are made aware of the increased risk of the presence of snakes.</p> <p>Wear proper protective clothing to protect against snake bites. An increased awareness and alertness is the best protection, the snake will not be looking for you, so watch for it. If a snake is seen or reported on site, note the area of the snake and work in this area stops until the hazard is removed. DO NOT approach, attack or otherwise provoke the snake as 95% of those bitten have done this. REMEMBER - IF PROVOKED IT WILL STRIKE.</p> <p>If bitten, the following procedures should apply:</p> <ol style="list-style-type: none"> 1.Immediately apply a broad firm bandage around the limb and on the bitten area. It should be as tight as one would bind a sprained ankle. As much of the limb should be bandaged as possible. Bind from below upwards. Crepe bandages are ideal, but any flexible material can be used, eg tear up clothing or old towels into strips. Panty hose is satisfactory. 2.Keep the limb and the victim as still as possible. Splint the limb. 3.Bring transport to the victim if possible. 4.Leave the bandage and splint on until medical care is reached. <p>Don't cut or excise the bitten area.</p> <p>Don't apply an arterial tourniquet.</p> <p>Don't wash the bitten area. The snake involved may be identified by the detection of venom on the skin.</p>	<p>Risk reduction/control/avoidance</p>

What is the risk?	Bees
Hazard Identification?	Being stung by bees
Who will be injured & mechanism of injury?	Personnel working on site
Preventative action recommended	
Description	Category: Reduction/transfe r/control/avoidan

For office use only	Version no: 2	Date: 20 October 2014
To be signed upon appointment of winning bidder to form the agreement between the parties		
Signature for Casidra		Signature for Contractor

		ce
<p>Upon finding a bee hive/nest, do not try to get rid of the nest or hive yourself. Each type of insect or situation will likely need different removal methods. It is best to call pest control professionals for this service.</p> <p>Upon being stung, most people experience local effects like pain, swelling, itching, and redness around the sting site. In rare cases, a severe allergic reaction can occur. This situation is serious and can cause "anaphylaxis" or anaphylactic shock. Symptoms of anaphylaxis can appear immediately (within minutes) or up to 30 minutes later. Symptoms to watch for include:</p> <ul style="list-style-type: none"> • hives, itching and swelling in areas other than the sting site, • swollen eyes and eyelids, • wheezing, • tightness in the chest and difficulty breathing, • hoarse voice or swelling of the tongue, • dizziness or sharp drop in blood pressure, • shock, • unconsciousness or cardiac arrest. <p>Although most deaths result from severe allergic reactions, some are caused by direct toxicity of the insect venom. Of those who die from a severe allergic reaction to a sting, half die within 30 minutes, and three-quarters within 45 minutes. If you see any signs of reaction, or even if you are not sure, call or have a co-worker call emergency medical services right away. Also, get medical help if the sting is near the eyes, nose or throat. People who have been stung multiple times (such as when fleeing from a swarm or nest) can sometimes suffer serious health effects. While rare, death may occur.</p> <p>Employers should be notified if a worker, especially one who works outdoors, has allergies to insect stings. Co-workers should be trained in emergency first aid, be aware of the signs of a severe reaction, and know how to use the bee sting kit (self-injectable epinephrine). Always carry a cellular phone in case you need emergency medical help.</p> <p>The best way to prevent stings is to avoid the insects. Leave the area, if possible. If there is a travelling swarm, they will likely leave within a few days.</p> <p>Note that insect repellent ("bug spray") does not affect these stinging insects. Avoidance and awareness are the keys to not being stung.</p>		<p>Risk avoidance/control/education/transfer</p>

For office use only	Version no: 2	Date: 20 October 2014	
To be signed upon appointment of winning bidder to form the agreement between the parties			
Signature for Casidra		Signature for Contractor	

Before working at a site:

- Take a look around. Check to see if there are any visible signs of activity or a hive or nest. If you see a number of insects flying around, check to see if they are entering/exiting from the same hole or place. If so, it is likely a nest or a source of food.
- Wear long sleeve shirts, and long pants. If you cannot avoid working near bees or wasps, wear a bee-keepers style hat with netting to cover your head, neck and shoulders. Tape your pant legs to your boots/socks, and your sleeves to your gloves. You may also wish to wear an extra layer of clothing since wasp stings are long enough to reach through one layer of clothing.
- Power tools such as lawnmowers, weed eaters and chainsaws will aggravate the insects. When using these tools, be aware that the tools may provoke the insects or in some cases, cause the insects to swarm.

If you find you are working near stinging insects, here are some tips.

- Most bees and wasps will not sting unless they are startled or attacked. Do not swat at them or make fast movements. The best option is to let the insects fly away on their own. If you must, walk away slowly, or gently "blow" them away. The only exception is if you have disturbed a nest and hear "wild" buzzing. Protect your face with you hands and run from the area immediately.
- Wear light coloured clothes such as khakis, beige, or blue. Avoid brightly coloured, patterned, or black clothing.
- Tie back long hair to avoid bees or wasps from getting entangled in your hair.
- Be careful when shaking out clothing or towels as the insects could be inside the folds.
- If you find a bee or wasp in your car, take a thick cloth and cover the insect before it gets frightened. Carefully, let the insect back outside through an open window.

For office use only	Version no: 2	Date: 20 October 2014	
To be signed upon appointment of winning bidder to form the agreement between the parties			
Signature for Casidra		Signature for Contractor	

DO NOT	
<ul style="list-style-type: none"> Do not wear perfumes, colognes, scented soaps, or powders as they contain fragrances that are attractive. Do not go barefoot or wear sandals, especially in areas where there is clover or other flowering plants that attract bees. 	

6. Risk assessments based on scope of work (Is this a high rise building in a built up area? Is it working in a flood plain and/or river with eroded soil conditions?)

What is the risk?	Structural stability
Hazard Identification?	Unstable working platforms could cause risk of collapse on trenches. Risk of excavations collapsing and burying or injuring people working in them; material falling from the sides into any excavation; and people or plant falling into excavations
Who will be injured & mechanism of injury?	Risk that people be killed or seriously injured by collapses and falling materials while working in excavations
Preventative action recommended	
Description	Category: Reduction/transfer/control/avoidance
<p><u>COLLAPSE OF EXCAVATIONS</u> Temporary support – Before digging any trench pit, tunnel, or other excavations, decide what temporary support will be required and plan the precautions to be taken. Make sure the equipment and precautions needed (trench sheets, props, baulks etc) are available on site before work starts. Battering the excavation sides – Battering the excavation sides to a safe angle of repose may also make the excavation safer.</p> <p>In granular soils, the angle of slope should be less than the natural angle of repose of the material being excavated. In wet ground a considerably flatter slope will be required</p> <p><u>FALLING OR DISLODGING MATERIAL</u> Loose materials – may fall from spoil heaps into the excavation. Edge protection should include</p>	Risk reduction/avoidance

For office use only	Version no: 2	Date: 20 October 2014	
To be signed upon appointment of winning bidder to form the agreement between the parties			
Signature for Casidra		Signature for Contractor	

toeboards or other means, such as projecting trench sheets or box sides to protect against falling materials. Head protection should be worn.

Undermining other structures – Check that excavations do not undermine scaffold footings, buried services or the foundations of nearby buildings or walls. Decide if extra support for the structure is needed before you start. Surveys of the foundations and the advice of a structural engineer may be required.

Effect of plant and vehicles – Do not park plant and vehicles close to the sides of excavations. The extra loadings can make the sides of excavations more likely to collapse.

FALLING INTO EXCAVATIONS

Prevent people from falling – Edges of excavations should be protected with substantial barriers where people are liable to fall into them. To achieve this, use:

- Guard rails and toe boards inserted into the ground immediately next to the supported excavation side; or
- fabricated guard rail assemblies that connect to the sides of the trench box
- the support system itself, eg using trench box extensions or trench sheets longer than the trench depth.

INSPECTION

A competent person who fully understands the dangers and necessary precautions should inspect the excavation at the start of each shift. Excavations should also be inspected after any event that may have affected their strength or stability, or after a fall of rock or earth. A record of the inspections will be required and any faults that are found should be corrected immediately.

Who will be injured & mechanism of injury?	Public will be injured and/or killed
---	--------------------------------------

For office use only	Version no: 2	Date: 20 October 2014	
To be signed upon appointment of winning bidder to form the agreement between the parties			
Signature for Casidra		Signature for Contractor	

Preventative action recommended	
Description	Category: Reduction/transfe r/control/avoidan ce
Construction work should be fenced off and suitably signed. This will protect people (especially children) from site dangers and the site from vandalism and theft. Site access should be monitored and controlled and all access routes should be clearly demarcated. A constant regard must be taken to safety and dangerous areas and should be adequately cordoned off to prevent accidental injury. Temporary fencing/hoarding with appropriate warning signs must be in place. Make sure there is a system to ensure necessary precautions are kept in place during working hours and that night-time and weekend protection is put in place as required before the site closes	

What is the risk?	Working at heights
Hazard Identification?	Risks of falling material, tools & personel
Who will be injured & mechanism of injury?	People/Infrastructure being struck by falling material & tools causing injury or even death. The same for personell falling from heights.

Preventative action recommended	
Description	Category: Reduction/transfe r/control/avoidan ce
<p>Avoid working at heights where you can. Use work equipment to prevent falls where work at height cannot be avoided. Where the risk of a fall cannot be eliminated, use work equipment to minimise the distance and consequences of a fall should one occur. Always consider measures that protect all those at risk, ie</p> <ul style="list-style-type: none"> ■ collective protection measures (scaffolds, nets, soft landing systems) before measures that only protect the individual, ie personal protection measures (a harness). <p>Ensure work is carried out only when weather conditions do not jeopardise the health and safety of the workers.</p>	Risk reduction/avoidance/control

For office use only	Version no: 2	Date: 20 October 2014
To be signed upon appointment of winning bidder to form the agreement between the parties		
Signature for Casidra		Signature for Contractor

<p>Suitable precautions must be taken to prevent falls. General access scaffolds provide a means of working at height while preventing falls and should be provided whenever practicable. Scaffolds should be designed, erected, altered and dismantled only by competent people and the work should always be carried out under the direction of a competent supervisor.</p> <p>Ensure the scaffold is based on a firm, level foundation. The ground or foundation should be capable of supporting the weight of the scaffold and any loads likely to be placed on it. Ensure it is braced and tied into a permanent structure or otherwise stabilised.</p>	
--	--

7. Equipment Risks

What is the risk?	Heavy Mechanized equipment
Hazard Identification?	Close proximity to labour force on ground working together in combined operations gives risk of collision
Who will be injured & mechanism of injury?	Infrastructure damage, damage to plant equipment/constructed items and personnel injury will vary from dislocation, broken bones to death
Preventative action recommended	
Description	Category: Reduction/transfe r/control/avoidan ce
<p>This is specialized work that requires competent human resources that are adequately skilled in working with heavy and dangerous equipment.</p> <p>Guidelines and practical advice to all work operations to ensure effective and proper management of working with mechanical plant must be in place. Toolbox talks MUST make all personnel aware of the dangers. Equipment must be checked for proper working controls such as reverse warning sirens, etc.</p> <p>Make sure equipment is in good working order each and every day and before every single operation. All workers should wear bright protective clothing and signs that are highly visible.</p>	Risk Control

For office use only	Version no: 2	Date: 20 October 2014
To be signed upon appointment of winning bidder to form the agreement between the parties		
Signature for Casidra		Signature for Contractor

--	--

8. Material Risks.

What is the risk?	Storage of materials	
Hazard Identification?	Tripping/ Flammable materials igniting	
Who will be injured & mechanism of injury?	Material/Infrastructure & personell	
Preventative action recommended		
Description	Category: Reduction/transfe r/control/avoidan ce	
<p>Designate storage areas for plant, materials, waste, flammable substances (eg foam plastics, flammable liquids and gases such as propane) and hazardous substances (eg pesticides and timber treatment chemicals). Flammable materials will usually need to be stored away from other materials and protected from accidental ignition. Do not store materials where they obstruct access routes or where they could interfere with emergency escape, eg do not store flammable materials under staircases or near to doors or fire exits.</p> <p>If materials are stored at height (eg on top of a container or on a scaffold gantry), make sure necessary guard rails are in place if people could fall when stacking or collecting materials or equipment. Keep all storage areas tidy, whether in the main compound or on the site itself.</p> <p>Try to plan deliveries to keep the amount of materials on site to a minimum. Waste materials also need storing safely before their removal from the site and make sure that you allow sufficient space for waste skips and bins.</p>	Risk Control	

What is the risk?	Flammable material	
Hazard Identification?	Dangerous to work with and store for prevention of fires	
Who will be injured & mechanism of injury?	Infrastructure damage and injury or death to all persons	
Preventative action recommended		
Description	Category: Reduction/transfe r/control/avoidan	

For office use only	Version no: 2	Date: 20 October 2014	
To be signed upon appointment of winning bidder to form the agreement between the parties			
Signature for Casidra		Signature for Contractor	

	ce
<p>Fuels and flammable materials should be stored in suitably equipped storage areas demarcated within the Contractor's camp. These areas must comply with general fire safety requirements. No fuel may be stored within drainage lines or areas. Impervious lining materials should be used in these storage areas to prevent contamination of the ground in the event of spillages or leaks, and automatic shut-off nozzles should be used on all dispensing units. Quantities of fuels and flammable/hazardous materials stored on site should be appropriate to the requirement for these substances on site.</p> <p>Fuels and oils should be safely located out of harm's way from the elements. No fuel / oil containers may be left unattended within drainage areas. All open containers containing used oil, etc., should be kept under roof or have adequate water tight lids. All spills to be immediately contained, reported to the Project Manager and dealt with.</p> <p>Adequate fire fighting equipment should be available on site, in good working order, and according to the fire hazard present during construction activities of at least one type ABC all-purpose 12.5kg extinguisher and a water cart with a minimum capacity of 1000 litres for the duration of the contract. Any welding, gas cutting or cutting of metal should only be permitted inside the demarcated working areas for this purpose and these areas should be approved by the Project Manager.</p>	Risk control

What is the risk?	Fire
Hazard Identification?	Flammable materials are always evident on construction site and danger of fire is always constant
Who will be injured & mechanism of injury?	Material/Infrastructure & personnel
Preventative action recommended	
Description	Category: Reduction/transfer/control/avoidance
Fire can be a particular hazard in refurbishment/new work when there is a lot of dry timber and at the later stages of building jobs where flammable materials such as adhesives, insulating materials and soft furnishings are present.	Risk reduction/transfer/control/avoidance

For office use only	Version no: 2	Date: 20 October 2014
To be signed upon appointment of winning bidder to form the agreement between the parties		
Signature for Casidra		Signature for Contractor

<p>Many fires can be avoided by careful planning and control of work activities.</p> <p>Good housekeeping and site tidiness are important not only to prevent fire, but also to ensure that emergency routes do not become obstructed. Making site rules can help.</p>	
--	--

9. Ergonomic Risks (Ergonomic hazards refer to workplace conditions that pose the risk of injury to the musculoskeletal system of the worker).

What is the risk?	Health
Hazard Identification?	On-site injuries due to physical construction work taking place
Who will be injured & mechanism of injury?	Personnel suffering ill-health
Preventative action recommended	
Description	Category: Reduction/transfer/control/avoidance
<p>Construction workers are likely to suffer ill health as a result of their work in the industry after exposure to both harsh working conditions and hazardous substances.</p> <p>Assess both immediate risks, eg being overcome by fumes in a confined space, and longer-term health risks. Materials like cement can cause dermatitis. Sensitizing agents like isocyanates can make people using them have sudden reactions, even though they may have used the substance many times before.</p> <p>If harm from the substance is possible, the first step to take is to try and avoid it completely by not using it at all. try and control exposure. Some of the ways this could be done include: Keep containers closed except when transferring; using cutting and grinding tools and blasting equipment fitted with exhaust ventilation or water suppression to control dust; ensuring good ventilation in the working area by opening doors, windows and skylights.</p> <p>The need to provide personal protective equipment (PPE) is also a must and will contribute in minimizing exposure risks. Respirators can protect against dusts, vapours and gases. Ear plugs for noise, etc. Where protective clothing is provided (such as overalls and gloves), it must be</p>	Risk reduction/transfer/control/avoidance

For office use only	Version no: 2	Date: 20 October 2014
To be signed upon appointment of winning bidder to form the agreement between the parties		
Signature for Casidra		Signature for Contractor

<p>of the right type to protect the wearer against the particular hazard they are going to encounter. All manufacturers offer advice on the most suitable gloves for specific types of hazard. When using gloves to help prevent dermatitis, users must avoid getting contaminants inside the gloves when putting them on and taking them off. It is also essential to provide washing facilities, with a supply of hot and cold (or warm) running water, soap and a means of drying the hands, to help prevent dermatitis.</p> <p>First aid can save lives, reduce pain and help an injured person make a quicker recovery. Provide adequate and appropriate equipment, facilities and personnel to enable first aid to be given to your employees if they are injured or become ill at work. The minimum provision for all sites is:</p> <ul style="list-style-type: none"> • a first aid box with enough equipment to cope with the number of workers on site; • an appointed person to take charge of first-aid arrangements; • information telling workers the name of the appointed person or first aider and where to find them. 	
--	--

10. Controls specific to client requirements (two day induction, pink overalls, entrance to existing premises, etc).

No work after 17h00 and only on weekdays

11. Personal Protective Equipment (PPE) and Clothing

The principal contractor and other contractors shall ensure that all workers are issued with protective clothing free of charge and make use of the equipment and protection provided such as to wear hard hats, protective footwear, overalls, etc. The Principal Contractor and all Contractors shall make provision and keep adequate quantities of SABS approved PPE on site at all times. The Principal Contractor shall clearly outline procedures to follow when PPE or Clothing is:

- Lost or stolen;
- Worn out or damaged

For office use only	Version no: 2	Date: 20 October 2014	
To be signed upon appointment of winning bidder to form the agreement between the parties			
Signature for Casidra		Signature for Contractor	

The above procedure applies to Contractors and their Sub-contractors, as they are all employers in their own right, as per section 37 (2) of the Act.

(The general PPE requirements are attached under Annexure A to this document as well as an additional list of PPE for biomass removal is also attached as Addendum B to this specification).

12. Occupational Health and Safety signage

The Contractor shall provide and maintain adequate on-site OHS signage. Including but not limited to: 'no unauthorised entry', 'report to site office', 'beware of overhead work', 'hard hats, overalls, safety boots, respirators, etc'. Signage shall be posted up at all entrances to site as well as on site in strategic locations e.g. access routes, stairways, entrances to structures and buildings, scaffolding, and other potential risk areas/operations

13. Fences and access

Construction sites in built-up areas or adjacent to public roads must be suitable and sufficiently fenced off and provided with controlled access points to prevent the entry of unauthorised persons.

14. Admittance to site

A notice must be posted up at every entrance to a building site prohibiting the entry of unauthorised persons to such workplace and no person shall enter such a site without the permission of the employer or user as the case may be. In no circumstances may the wording "Enter at Own Risk" be used

15. Speed Restrictions, construction vehicles and Protection

The Principal Contractor shall ensure that all persons in its employment, all Contractors, and all those that are visiting the site are aware and comply with the site speed restriction(s) and route identification for construction vehicles only. Separate vehicle and pedestrian access routes shall be provided, maintained, controlled, and enforced.

16. Hazardous Chemical Substances (HCS)

The Principal Contractor and other relevant Contractors shall provide the necessary training and information regarding the use, transport, and storage of HCS. The Principal Contractor shall ensure that the use, transport, and storage of HCS is carried out as prescribed by the HCS Regulations. The Contractor shall ensure that all hazardous chemicals on site have a Material Safety Data Sheet (MSDS) on site and the users are made aware of the hazards and precautions that need to be taken when using the chemicals. The First Aiders must be made aware of the MSDS and how to treat HCS incidents appropriately.

The below acts are relevant regarding the transporting, storage and application of these agricultural chemicals:-

For office use only	Version no: 2	Date: 20 October 2014	
To be signed upon appointment of winning bidder to form the agreement between the parties			
Signature for Casidra		Signature for Contractor	

- Fertilizers, farm feeds, agricultural remedies and stock remedies act, 1947 (Act no. 36 of 1947)
- Hazardous Substances Amendment Act, No. 53 of 1992
- The South African National Pesticide registration authority registrar: Act no. 36 of 1947

17. Public and Site Visitor Health and Safety

The Principal Contractor shall ensure that every person working on or visiting the site, as well as the public in general, shall be made aware of the dangers likely to arise from site activities, including the precautions to be taken to avoid or minimise those dangers. Appropriate health and safety notices and signs shall be posted up, but shall not be the only measure taken.

The Principal Contractor has a duty in terms of the OHS Act 85/1993 to do all that is reasonably practicable to prevent members of the public and site visitors from being affected by the construction activities.

Site visitors must be briefed on the hazards and risks they may be exposed to and what measures are in place or should be taken to control these hazards and risks. A record of these 'inductions' must be kept on site in accordance with the Construction Regulations.

18. Occupational Hygiene

Exposure of workers to occupational health hazards and risks is very common in any work environment, especially in construction. Occupational exposure is a major problem and all contractors must ensure that proper health and hygiene measures are put in place to prevent exposure to these hazards. Prevent inhalation, ingestion, absorption, and noise induction.

Contractor must identify site-specific health risks for construction. e.g. cement dust, wet cement, wood-dust, noise, etc.

19. Welfare Facilities

The Principal Contractor must supply the following clean, hygienic and maintained facilities:

- Shower facilities, after consultation with employees or employee representative (1 shower for every 15 persons).
- Sufficient toilets (1 toilet per 30 workers) and hand washing facilities. Separate toilets needed for both males and females. Toilet paper must be provided.
- Changing facilities for each sex

For office use only	Version no: 2	Date: 20 October 2014	
To be signed upon appointment of winning bidder to form the agreement between the parties			
Signature for Casidra		Signature for Contractor	

- Sheltered eating areas
- Waste bins must be strategically placed and emptied regularly.

Workers who are far removed from their homes, reasonable and suitable living accommodation for the workers must be provided and adequate transportation between sites and homes where suitable living accommodation is not available.

20. Alcohol and other Drugs

No alcohol and other drugs will be allowed on site. No person may be under the influence of alcohol or any other drugs while on the construction site. Any person on prescription drugs must inform his/her superior, who shall in turn report this to the Principal Contractor forthwith. Any person suffering from any illness/condition that may have a negative effect on his/her safety performance must report this to his/her superior, who shall in turn report this to the Principal Contractor forthwith. Any person suspected of being under the influence of alcohol or other drugs must be sent home immediately, to report back the next day for a preliminary inquiry. A full disciplinary procedure must be followed by the Contractor concerned and a copy of the disciplinary action must be forwarded to the Principal Contractor for his records.

21. Other compliance requirements

Notwithstanding the Occupational Health & Safety Act, the contractor must also confirm to the following acts:

- Basic conditions of employment act 75 of 1997
- National Road Traffic Act 93 of 1996
- National Environmental Management: Biodiversity Act, no 10 of 2004
- National Veld and Forest Fire Act, no 101 of 1998.
- Fertilizers, Farm Feeds, Agricultural Remedies and Stock Remedies Amendment act

22. Management control measures and review

23. Risk assessment of the site must be reviewed at least every 30 days. Based on the effectiveness of the existing measures, the safety plan must be adjusted to meet the new or existing identified deficiencies.

24. Electrical Safety

All persons who carry out or arrange for work of any description for Casidra in connection with **electrical apparatus** shall make themselves acquainted with the Occupational Health and Safety Act (Act 85 1993) with particular reference to the Electrical Machinery Regulations, Regulations 1 to 23 inclusive.

For office use only	Version no: 2	Date: 20 October 2014	
To be signed upon appointment of winning bidder to form the agreement between the parties			
Signature for Casidra		Signature for Contractor	

The works performed under this contract shall comply in every respect with the latest relevant rules and regulations including following:

- Occupational Safety and Health Act (OSH Act)
- The South African Bureau of Standards Code of Practice SANS 10142
- Normal requirements laid down by Eskom.
- The latest requirements of the IEC and the British Standard Institute, where no SANS codes of practice exist.
- All rules and regulations issued by local and other authorities having jurisdiction over the contract.

The contractor must, in addition to compliance with the Electrical Installation Regulations, 2009, and the Electrical Machinery Regulations, 1988, promulgated by Government Notice No. R. 1593 of 12 August 1988, ensure that —

- (a) before construction commences and during the progress thereof, adequate steps are taken to ascertain the presence of and guard against danger to workers from any electrical cable or apparatus which is under, over or on the site;
- (b) all parts of electrical installations and machinery are of adequate strength to withstand the working conditions on construction sites;
- (c) the control of all temporary electrical installations on the construction site is designated to a competent person who has been appointed in writing for that purpose;
- (d) all temporary electrical installations used by the contractor are inspected at least once a week by a competent person and that inspection findings are recorded in a register kept on the construction site; and
- (e) all electrical machinery is inspected by the authorized machine operator or user on a daily basis using a relevant checklist prior to use and the inspection findings are recorded in a register kept on the construction site

NOTE:

The Electrical Installation Regulations clause 6 (2) require electrical contractors to register annually.

“(2) Any person who does electrical installation work as an electrical contractor shall register annually in the form of Annexure 3 with the chief inspector or a person appointed by the chief inspector “

In terms of the OHS Act Electrical Installation Regulations, a Certificate of Compliance (CoC) must be issued by a registered person, defined as “a person registered as an electrical tester for single phase, an installation electrician, or a master installation electrician”. Registered

For office use only	Version no: 2	Date: 20 October 2014	
To be signed upon appointment of winning bidder to form the agreement between the parties			
Signature for Casidra		Signature for Contractor	

persons may be the owners or employees of electrical contractors. They must be currently registered with the Department of Labour (DoL), and registrations must be renewed annually, bi-annually or every three years depending on the application. No company may do electrical contracting work unless they have a permanently employed registered person as part of the company.

Department of Labour stating the certification as either ‘single phase tester”, “installation electrician” or “master installation electrician” with a unique licence number

Safety equipment

The following equipment required for working on electrical installations and distribution systems, must be maintained in good order and repair and must be made available:-

Safety belt, overalls, hard hat, safety shoes or boots, rubber gloves, "Men Working" notice boards, locks for locking off switches, buss bar shutters in truck-type switchgear, isolators or earthing links, rubber sheet and length of rope with short circuiting earthing-chains, earthing sticks and testing/phasing sticks rated for the voltage of the equipment to be tested.

Under no circumstances shall work be carried out on electrical apparatus unless the proper safety equipment is used

With regard to overhead linesmen, no work shall be carried out unless use is made of a non-metallic ladder and the appropriate safety belt, rubber gloves, overalls, hardhat and safety shoes or boots are worn. The buddy system must also be implemented.

Earthing

Always safety test before applying earths

Risk assessment of the site must be reviewed at least every 30 days. Based on the effectiveness of the existing measures, the safety plan must be adjusted to meet the new or existing.

At completion of the electrical installation work in the tender, a test as required must be performed to ensure safe operation of the equipment and a signed original CoC be supplied to the client.

For office use only	Version no: 2	Date: 20 October 2014	
To be signed upon appointment of winning bidder to form the agreement between the parties			
Signature for Casidra		Signature for Contractor	

ADDENDUM A – GENERAL MINIMUM PPE REQUIREMENTS

Subject	Requirement
*PPE needs analysis	Need for PPE identified and prescribed in writing. PPE remain property of Employer, not to be removed from premises GSR 2(4)
*Head Protection	All persons on site wearing Safety Helmets including Sub-contractors and Visitors (where prescribed)
*Foot Protection	All employees on site wearing Safety Footwear including Gumboots for concrete / wet work and non-slip shoes for roof work. Visitors to wear same upon request or where prescribed
*Eye and Face Protection	<u>Eye and Face (also Hand and Body) Protection</u> (Goggles, Face Shields, Welding Helmets etc.) used when operating the following: <ul style="list-style-type: none"> * Jack/ Kango Hammers * Angle / Bench Grinders * Electric Drills (Overhead work into concrete / cement / bricks * Explosive Powered tools * Concrete Vibrators / Pokers * Hammers & Chisels * Cutting / Welding Torches * Cutting Tools and Equipment * Guillotines and Benders * Shears * Sanders and Sanding Machines * CO2 and Arc Welding Equipment * Skill / Bench Saws * Spray Painting Equipment etc.
*Hearing Protection	<u>Hearing Protectors</u> (Muffs, Plugs etc.) used when operating the following: <ul style="list-style-type: none"> * Jack / Kango Hammers * Explosive Powered Tools * Wood/Aluminium Working Machines e.g. saws, planers, routers
*Hand Protection	<u>Protective Gloves</u> worn by employees handling / using: <ul style="list-style-type: none"> * Cement / Bricks / Steel / Chemicals * Welding Equipment * Hammers & Chisels * Jack / Kango Hammers etc.
*Respiratory Protection	Suitable/efficient prescribed <u>Respirators</u> worn correctly by employees handling / using: <ul style="list-style-type: none"> * Dry cement * Dusty areas * Hazardous chemicals * Angle Grinders * Spray Painting etc.

For office use only	Version no: 2	Date: 20 October 2014	
To be signed upon appointment of winning bidder to form the agreement between the parties			
Signature for Casidra		Signature for Contractor	

*Fall Prevention Equipment	Suitable <u>Safety Belts</u> / Fall Arrest Equipment correctly used by persons working on / in unguarded, elevated positions e.g.: * Scaffolding * Riggers * Lift shafts * Edge work * Ring beam edges etc. Other methods of fall prevention applied e.g. catch nets
*Protective Clothing	All jobs requiring protective clothing (Overalls, Rain Wear, Welding Aprons etc.) Identified and clothing worn.
*PPE Issue & Control	Identified Equipment issued free of charge. All PPE maintained in good condition. (Regular checks). Workers instructed in the proper use & maintenance of PPE. Commitment obtained from wearer accepting conditions and to wear the PPE. Record of PPE issued kept on H&S File. PPE remain property of Employer, not to be removed from premises GSR 2(4)

For office use only	Version no: 2	Date: 20 October 2014	
To be signed upon appointment of winning bidder to form the agreement between the parties			
Signature for Casidra		Signature for Contractor	

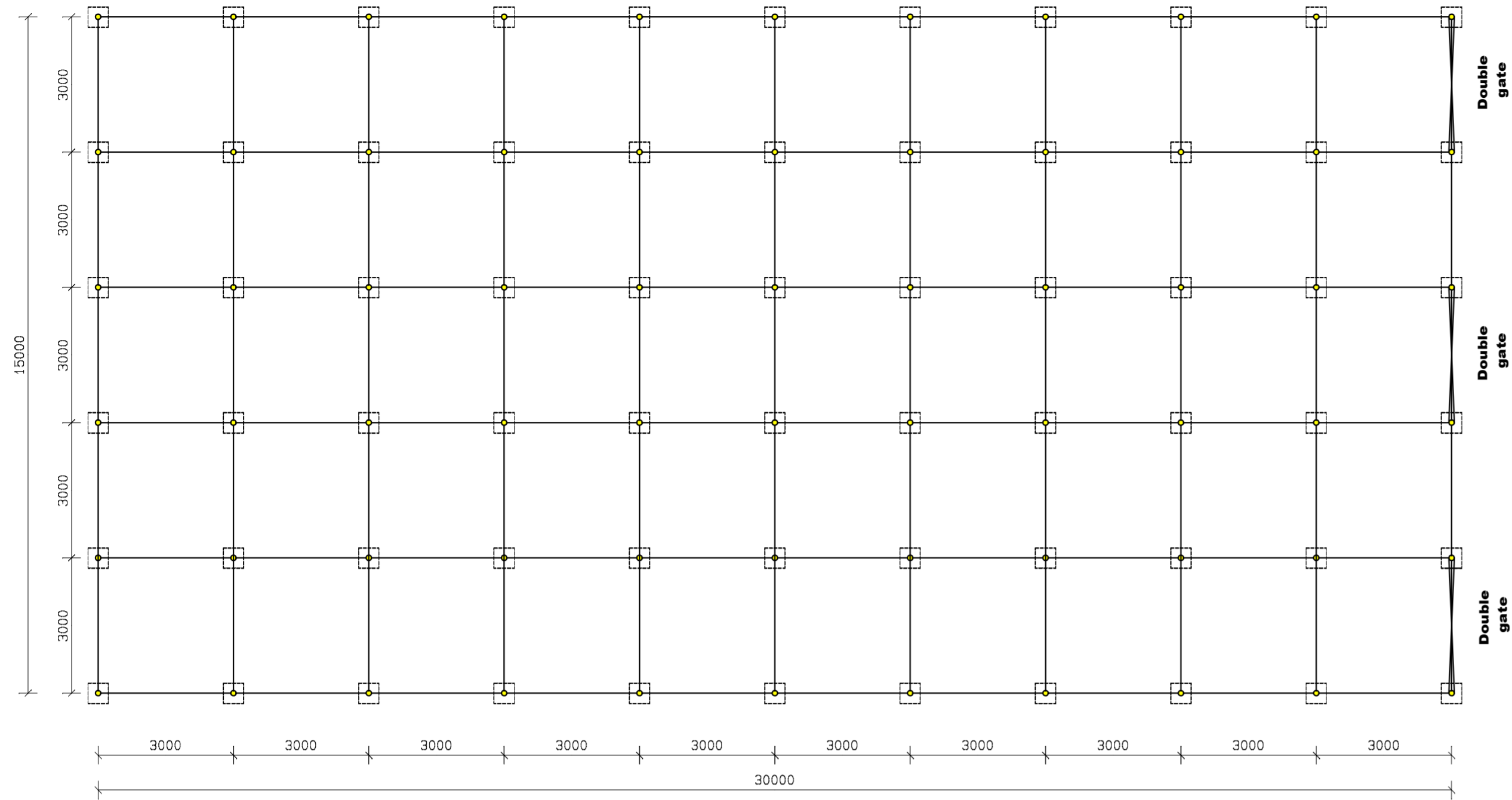

2.24mm Fully galvanized wire over the poles and fixed with 32mm long and 3.15mm thick barbed U-nails

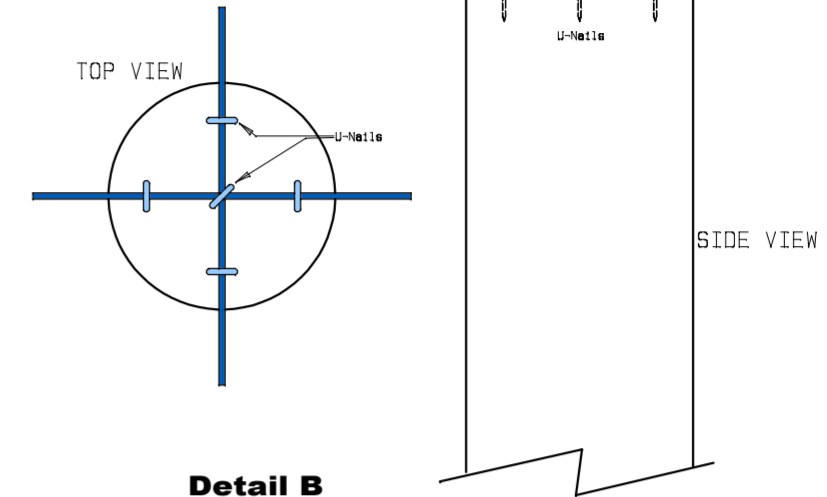

Cover complete structure, sides and roof with 40% shade cloth

2.24mm High tensile steel wire, fully galvanized @ max 500mm c/c.

Y-Steel anchors buried at minimum 600mm into ground

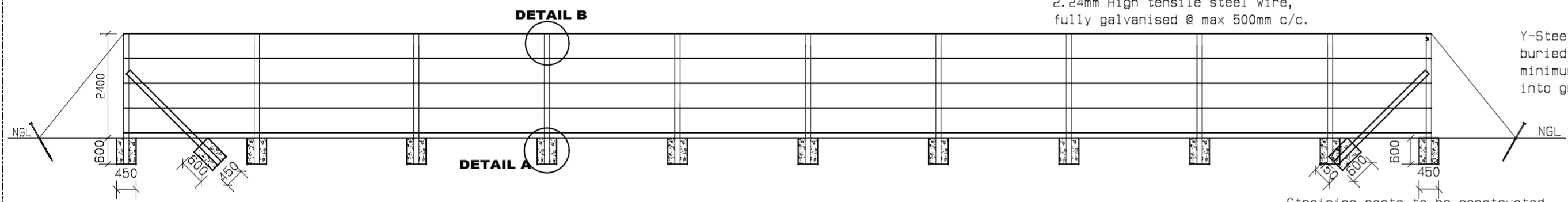

Shade cloth fixed to 53mm dia galvanized steel poles with 10mm galvanized threaded bar and galvanized nuts & washers. Cloth fixed around steel pole with 2.5mm thick galvanized binding wire.

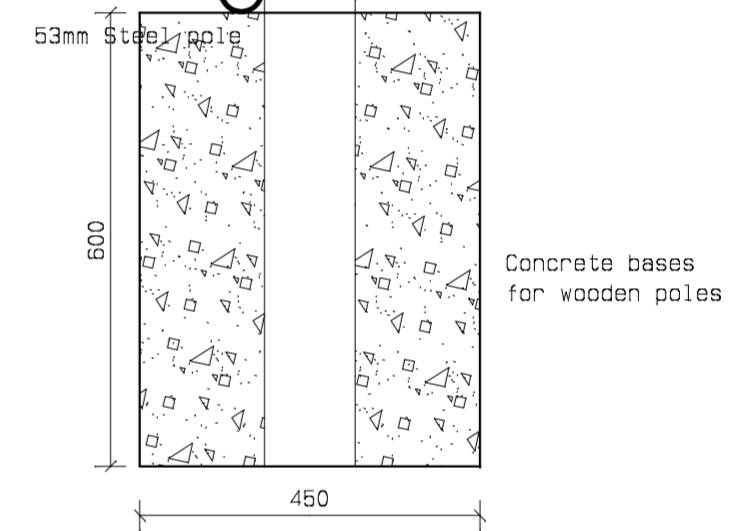

Straining posts to be constructed out of 100 - 119mm diameter wooden posts. Allow for straining posts on both sides of each corner

SIDE ELEVATIONS
Scale: 1:100

Cover complete structure, sides and roof with 40% shade cloth

Double gates to be constructed out of 35mm diameter galvanized framework and opening filled with 2.5mm thick, 50mm galvanized hexagon fencing material.

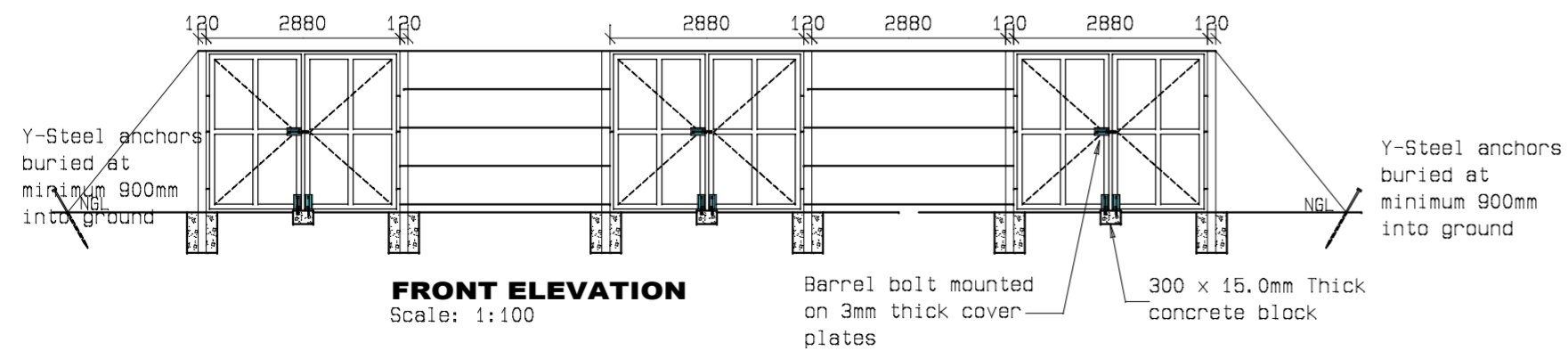

Y-Steel anchors buried at minimum 900mm into ground

REAR ELEVATION
Scale: 1:100

Y-Steel anchors buried at minimum 900mm into ground

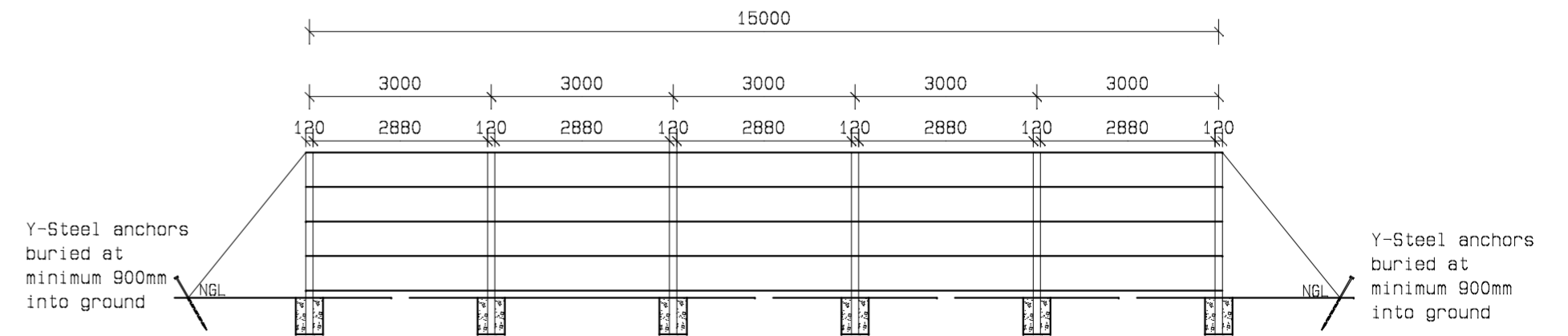

Barrel bolt mounted on 3mm thick cover
300 x 15.0mm Thick concrete block plates

WIRE TABLE LAYOUT

